



MAHAGROUP

C_RGA 7.5 | 8.5 UC

Mobile Column Lift

Original Operating Instructions

BA492501-en

Installation | Operation | Service

BA492501-en
2023-11-15

© MAHA Maschinenbau Haldenwang GmbH & Co. KG

The reproduction, distribution and utilisation of this document as well as the communication of its contents to others without explicit authorisation is prohibited. Offenders will be held liable for the payment of damages. All rights reserved in the event of the grant of a patent, utility model or design.

The contents have been checked with great care; however, errors cannot be fully excluded. Illustrations are examples and may differ from the original product. Subject to technical change without notice.

Manufacturer

MAHA Maschinenbau Haldenwang GmbH & Co. KG
Hoyen 20
87490 Haldenwang
Germany

Phone: +49 8374 585-0
Fax: +49 8374 585-590
Mail: maha@maha.de
Web: www.maha.de

Service

MAHA SERVICE CENTER
Maybachstraße 8
87437 Kempten
Germany

Phone: +49 8374 585-100
Fax: +49 8374 585-491
Mail: service@maha.de
Web: www.mahaservicecenter.de

Dear Customer,

MAHA is one of the world's leading manufacturers of testing and lifting technology and places particular emphasis on quality and performance. The company's concept includes the development, manufacture and sale of products for use in automotive workshops, by vehicle manufacturers and testing organisations.

MAHA's claim is to also be a leader in the areas of reliability, safety and sustainability – this can be seen in many details that have been developed with these aspects in mind.

We are convinced that you will be more than satisfied with the quality and performance of our products for many years. With the purchase of our products you will also receive professional assistance in case of need for service and repair.

Please remember to keep these operating instructions in a safe place. Accurately following their contents will significantly extend the life of your product and also increase its resale value. If you sell your product, please also pass on the operating instructions.

MAHA is constantly working on the further development of all products and therefore reserves the right to make changes, e.g. in shape and appearance, without prior notice.

Extensive accessories, useful assembly material and auxiliary materials are available for our products. For further information, please ask your dealer or your MAHA contact person at any time.

Thank you for choosing a MAHA product!

Contents

1	General Safety Instructions	7
1.1	Introduction	7
1.2	Symbols and Signal Words	7
1.2.1	Personal Injury	7
1.2.2	Property Damage	7
1.3	What to Do in the Event of Defects or Malfunctions	8
1.4	What to Do in the Event of an Accident	8
1.5	Requirements for the Operating Personnel	8
1.6	Requirements on Service Personnel	8
1.7	Intended Use	9
1.8	Inappropriate Use	9
2	System Description	10
2.1	Service Life	10
2.2	General Machine Description	10
2.1	Control Description	12
3	Safety Features	13
3.1	Emergency Stop	13
3.2	Dead Man	13
3.3	Synchronisation Control	13
3.4	Synchronisation Monitoring	13
3.5	Safety Catch	14
3.6	Obstacle Run	14
3.7	Motor Brake	14
3.8	Spindle Cover	15
3.9	Overload Protection	15
3.10	Overload Protection for Drive Motor	15
3.11	Warning and Information Signs	15
4	Technical Data	16
4.1	Overview with Components	16
4.2	Technical Data	17
4.3	Turning Circle	19
4.4	Danger Zone	19
5	Transport, Handling and Storage	21
5.1	Safety Instructions	21
5.2	Scope of Delivery	21
5.3	Packaging Information	21
5.3.1	Dimensions and Weight	21
5.3.2	Centre of Gravity of the Packaged Lift	22
5.4	Transport and Handling	22
5.4.1	Transport and Handling of the Lifting Columns	22
5.4.2	Transport and Handling of the Lithium-Ion Batteries	23
5.5	Storage	24
5.5.1	Storage of Lifting Columns	24

5.5.2	Storage and Fire Protection of Lithium-Ion Batteries	24
6	Installation and Initial Operation	25
6.1	Safety Instructions.....	25
6.2	Unloading Lifting Columns.....	25
6.3	Connecting Lifting Columns Electrically	25
7	Operation.....	26
7.1	Positioning the Lifting Columns	27
7.2	Adjusting the Vehicle Support.....	28
7.3	Picking up a Vehicle	29
7.4	Controls and Indicators	30
7.5	Switching on.....	31
7.6	Login Process (Pairing).....	31
7.6.1	Login Lifting Column.....	31
7.6.2	Connect Lifting Columns to Form a Network.....	31
7.6.3	Cancel Login Process	32
7.6.4	Error in a Column during Pairing	32
7.7	Lifting and Lowering.....	32
7.7.1	Driving up to an Obstacle.....	32
7.7.2	CE Stop	32
7.8	Radio Standby.....	33
7.9	ALL Operating Mode.....	33
7.10	SINGLE Operating Mode.....	33
7.11	GROUP Operating Mode.....	34
7.12	Fast Travel (SPEED).....	35
7.13	Switch off / Open Network.....	35
7.14	Radio Communication.....	35
7.15	Search New Radio Channel.....	36
7.15.1	Communication Error (Radio or Cable Error).....	37
7.15.2	Overview: Status of the Lifting Column Lamps	37
7.16	Cable Emergency Operation.....	38
7.16.1	Activate Cable Emergency Operation	38
7.16.2	End Cable Emergency Operation.....	38
7.17	Output Software Version Identifier	38
7.18	Charge Battery	39
8	Troubleshooting.....	40
8.1	Diagnostics	40
8.2	Error Codes	40
9	Inspection and Maintenance.....	42
9.1	Daily Checks before Starting Work	42
9.1.1	Cables and Actuating Elements	42
9.1.2	Emergency Stop	42
9.1.3	Illumination of the Control Unit	42
9.1.4	Locking the Adjustable Wheel Fork.....	43
9.1.5	Hydraulic Dolly.....	43
9.1.6	Load Handling Attachments.....	44

9.2	Six-Monthly Inspection	44
9.2.1	Spindles and Support Nuts	44
9.2.2	Running surfaces and Flange Rollers	45
9.2.3	Thrust Washers	45
9.2.4	Wear Test on Flange Rollers and Column	46
9.2.5	Spindle Lubrication, Spindle Lubrication Level	47
9.2.6	Intermediate Safety Wedge Inspection	47
9.2.7	Motor Retaining Ring	48
9.3	Yearly Inspection	49
9.3.1	Chassis Rollers	49
9.3.2	Screw Connections	49
9.3.3	Safety Wedge	50
9.3.4	Obstacle Run	52
9.3.5	Motor brake	52
9.3.6	Carriage	53
10	Servicing	55
10.1	Safety Instructions	55
10.2	Lubrication	55
10.2.1	Lubricating Spindle and Recirculating Ball Nut	56
10.2.2	Lubricating the Tracks of the Flange Rollers	57
10.2.3	Base Frame	57
10.2.4	Options	58
10.3	Replacing Flange Rollers and Axles	58
10.4	Every 5 years	59
11	Repairs	60
11.1	Manual Lowering	60
11.2	Operating Unit	61
11.2.1	Replacing Charger and Battery	62
11.2.2	Replacing Circuit Board, Emergency Stop Switch and Silicone Buttons	62
11.2.3	Replacing the Sockets for Cable Connection	63
11.3	Replacing Sensors	63
11.3.1	Replacing the Speed Sensor	64
11.3.2	Replacing Safety Sensor and Proximity Switch for Lower End Position	65
11.4	Drive Train	66
11.4.1	Replacing the Motor with Drive Pin	66
11.4.2	Replacing the Spindle with Bearing	67
11.5	Replacing Solenoid and Safety Wedge	68
11.6	Adjusting the Hydraulic Dolly	70
11.6.1	Adjusting the Lowering Speed	70
11.6.2	Adjusting the Automatic Lowering Function	71
11.6.3	Topping up the Hydraulic Oil on the Dolly	71
12	Decommissioning, Dismantling and Disposal	72
12.1	Disposal of Batteries	72
13	Control Board	72
13.1	Assignment of the DIP Switches	72

14	Configuration Program	73
14.1	Overview of Available Configurations	73
14.2	Start Configuration Program.....	73
14.3	Select Configuration Number.....	74
14.4	Display, Change and Save Configuration Value.....	74
14.5	Exit Configuration Program.....	74
15	Annex.....	75
15.1	Electric Circuit Diagrams.....	75
15.2	Product Datasheets.....	75
15.3	Declarations of Conformity.....	75

1 General Safety Instructions

1.1 Introduction

- These operating instructions must be read carefully and understood before work commences.
- Please observe the specific safety information provided for the respective sections of the operating instructions.
- Adhering to the procedures, sequences and corresponding safety instructions is essential.
- A printed copy of the operating instructions must always be kept by the lift.
- The relevant regulations regarding accident prevention and health and safety must be observed.

1.2 Symbols and Signal Words

1.2.1 Personal Injury



DANGER

indicates an immediate hazard which, if not avoided, will result in death or severe personal injury.



WARNING

indicates a potential hazard which, if not avoided, could result in death or severe personal injury.



CAUTION

indicates a potential hazard which, if not avoided, could result in moderate or minor personal injury.

1.2.2 Property Damage

NOTICE

indicates a potentially harmful situation which, if not avoided, could result in damage to the equipment or surrounding objects.

1.3 What to Do in the Event of Defects or Malfunctions

- If a malfunction occurs, e.g. uncontrolled raising and lowering or in the case of load-bearing components of the structure becoming deformed, immediately lower the lift to the ground to its initial position or support the structure.
- Turn off the main switch and secure against unauthorised use.
- Contact service team.

1.4 What to Do in the Event of an Accident

- Notify first aiders, the ambulance service and/or immediate care doctor:
 - Where did the accident happen (address, workshop, ...)?
 - What happened?
 - How many are injured?
 - What injuries have occurred?
 - Who is reporting the accident?
- Keep calm and answer questions.

1.5 Requirements for the Operating Personnel

All persons involved in the operation of the equipment must:

- be 18 years of age or older,
- have the mental and physical capacity for their role,
- be demonstrably trained and instructed in writing in the operation of the equipment,
- have read and understood the operating instructions, and in particular the instructions on the procedure in the event of a malfunction,
- show knowledge and experience in handling the equipment and the dangers posed,
- have had certified training regarding safety regulations.

1.6 Requirements on Service Personnel

Persons who are entrusted with the installation, maintenance and/or dismantling of the equipment must in addition:

- be demonstrably trained and instructed in the required work,
- can provide evidence of appropriate qualification for work on the electrical system of the equipment (e.g. as a qualified electrician),
- be able to demonstrate expertise for vehicle lifts. This includes sufficient knowledge in the field of lifts and the relevant statutory occupational health and safety regulations, accident prevention regulations and generally accepted rules of technology to be able to assess the safe working condition

of the lift to be tested.

Qualified persons shall not only consider the current condition of the lift during the inspection. They must also be able to estimate how the lift and its structural parts will behave under operational conditions in the sequence and how wear, aging and the like will affect the safety of the lift.

1.7 Intended Use

- This lift in the version with wheel forks is intended exclusively for the safe lifting and lowering of passenger cars and commercial vehicles as part of service and repair work. For lifting other vehicles and loads, suitable load handling attachments on lifting columns with flanged carriages must be used for this purpose.
- The permissible load according to the type plate must not be exceeded.
- Only vehicles which are suitable for the lifting equipment due to their shape and the positioning of their lifting points may be lifted.
- The lift may only be operated in the temperature range 5...40 °C at a maximum humidity of 50% (at 40 °C).
- The lift must be protected from direct weather influences at all times, e.g. by using the supplied transport protection hood.
- At wind speeds above 6 m/s, operation outside enclosed spaces must be stopped and the load lowered.
- The lift may only be operated on level and sufficiently load-bearing ground; ground inclination max. 1°.
- The lift may not be modified without express written permission from the manufacturer. Non-compliance invalidates the declaration of conformity.

1.8 Inappropriate Use

- Lifting vehicles and loads with load handling attachments not approved for this purpose is not permitted.
- Passenger transport, in particular the riding of persons with the load, is not permitted.
- Lifting the load with an additional hoist is prohibited.
- The lift must not be operated in potentially explosive and flammable operation rooms or in damp rooms (e.g. washing facilities).

2 System Description

2.1 Service Life

The lift has been tested in accordance with EN 1493 and is designed for a nominal load. The lift must be replaced with a new product after 10 years at the latest.

2.2 General Machine Description

Each lifting column consists of an H-profile with a welded-on base frame, a lifting carriage with load handling attachment, a drive unit, a control unit and a hydraulic dolly for positioning the lifting column.

Several lifting columns can be connected to a lifting system via radio modules.

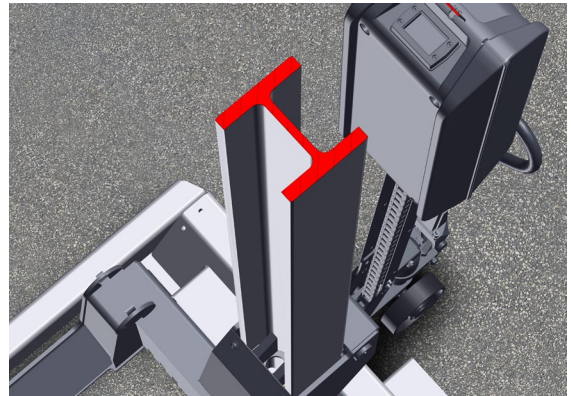

Lifting column profile ▲

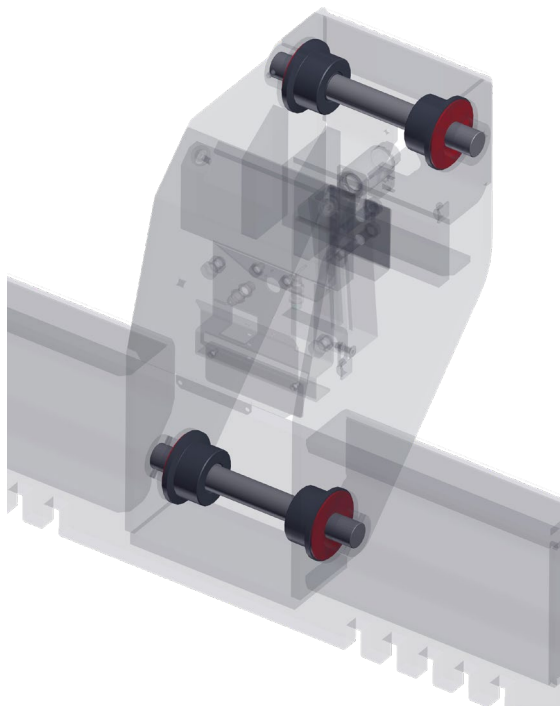

Recirculating ball nut ►

◄ Lifting carriage

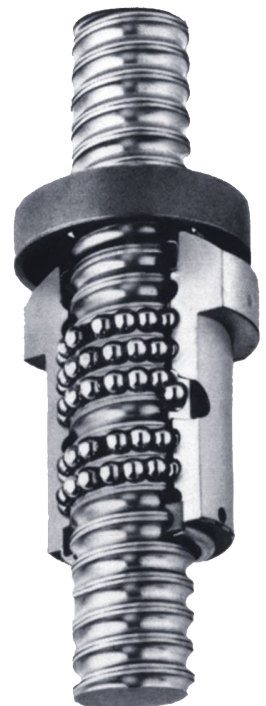

The lifting carriage encloses the column profile and is guided by four flanged rollers. Inside the lifting carriage is the recirculating ball nut, which – depending on the direction of rotation of the spindle – moves the lifting carriage up or down.

The lifting carriage can be designed either as a flanged or universal lifting carriage. The flanged lifting carriage is equipped with a flat front plate with six threads in which customer-specific load supports can be attached. The

universal lift carriage is equipped with adjustable and lockable wheel forks to lift vehicles with different wheel diameters.

The lifting drive consists of an electric motor with an electrically released brake, which turns the spindle via a worm gear. The anti-rotation nut in the lifting carriage triggers a lifting or lowering movement depending on the direction of rotation.

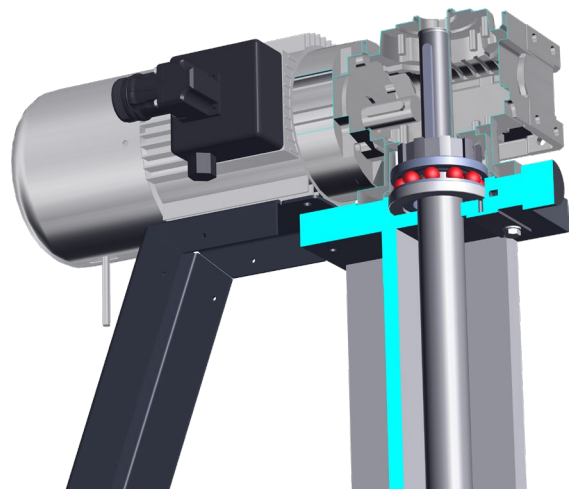

Worm geared motor with spindle ►

Lithium-ion batteries are located in the housing of the operating unit to power the mobile lifting column. AGM (Absorbent Glass Mat) batteries, which are mounted on the base frame, are also available as an option.

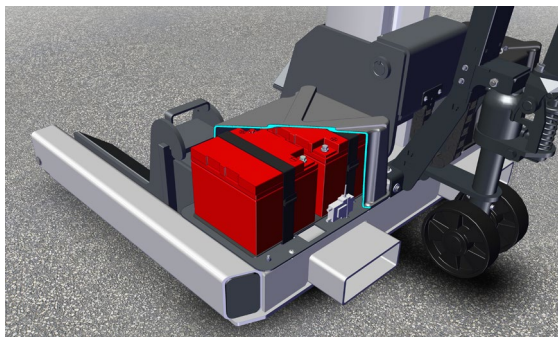

AGM battery (option) ▲



Li-ion battery (standard) ▲

Depending on the situation, an acoustic signal transmitter indicates any errors that have occurred and any operating errors.

The control unit is located on the back of the column. The operating unit makes it possible to create a network with other lifting columns and thus a complete lifting system, it implements all functions for safe operation and displays all operating states and faults that occur.

Proximity switches detect end positions, asynchronism and nut breakage. The relevant direction button light turns off to indicate when an end position has been reached.

2.1 Control Description

Each lifting column is equipped with its own control unit. At its heart is a control board that executes, monitors and controls all the electrical functions required for safe operation of the system. This control board is installed at the rear of the lifting column below the control panel.

Several lifting columns can be connected to form a lifting system via a radio module installed on the control board. With so-called "channel hopping", the column or the column network searches for a fail-safe radio channel that is not already occupied by another system after a movement command has been triggered.

This radio link transmits all the commands and information required for operation between the lifting columns of a lifting system.

Thanks to "channel hopping", an unlimited number of column groups can be operated in the same radio reception area at one location. Up to 15 column groups can be raised or lowered simultaneously.

The emergency stop, which is also located on the control panel, switches off all lifting columns in the network when pressed.

As an option, the lifting system can be operated with a plug-in cable remote control.

3 Safety Features



WARNING

Safety features must not be bypassed, blocked or otherwise rendered unusable.

3.1 Emergency Stop



WARNING

Even when the emergency stop is activated, the control unit is always energised (e.g. by battery or charging current). Before working on the electrical installation of the system, it must be disconnected from the power supply.

There is an emergency stop button on the control unit which, when pressed, interrupts the power supply to the drives of all the columns involved, thus putting the system into a safe state. This push-button can be unlocked by turning it clockwise.

Automatic restarting after unlocking is prevented.

3.2 Dead Man

The buttons for raising and lowering are designed with automatic reset (dead man's switch), which ensures that the move command is only executed while the button is pressed.

3.3 Synchronisation Control

The load supports of the lifting columns move up and down synchronously. The control system of the lift detects height differences and keeps the lifting height of the columns involved within a range of approx. ± 15 mm.

3.4 Synchronisation Monitoring

If, for whatever reason, the synchronisation control does not work properly, the system's synchronisation monitoring function kicks in. If the lifting heights drift apart by more than 50 mm, the control switches off the system to prevent a dangerous misalignment.

3.5 Safety Catch

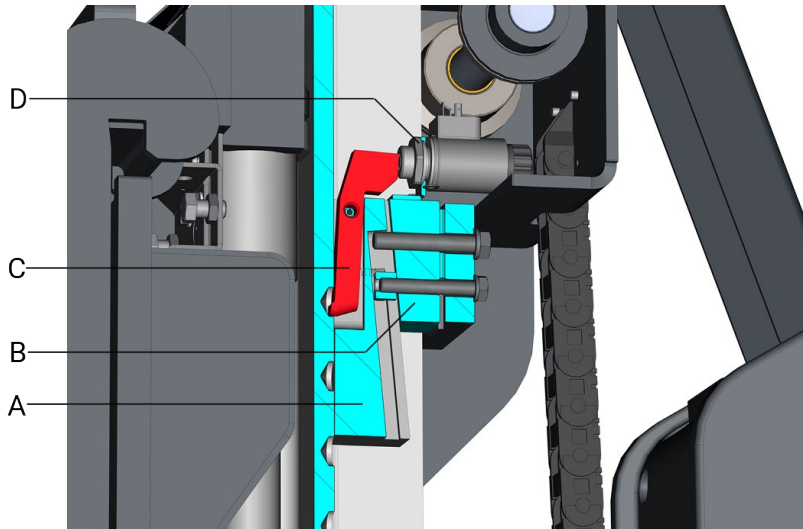

The safety catch essentially consists of two oppositely arranged steel wedges (A, B), which are fitted between the rear of the lifting column and the lifting carriage.

In the event of a fault, e.g. if the support nut breaks, a claw (C) engages in a notch of the column and thus blocks one of the two wedges. The forced downward movement of the second wedge displaces the two against each other. The lifting carriage and column are jammed against each other and the lifting carriage comes to a standstill.

In normal operation, pressing the DOWN button de-energises the solenoid (D) and thus unlocks the safety catch.

3.6 Obstacle Run

NOTICE

The system detects a blockage of the load handling attachment, but no obstacles under the vehicle.

If the load support or the lifting carriage is blocked during lowering, the spindle nut loses the connection to the lifting carriage or moves further down.

The sensor in the lifting carriage sends a signal and the control unit detects a blockage when lowering.

3.7 Motor Brake

The drive motor is equipped with an automatic spring-applied brake. This brake is dimensioned in such a way that it is able to stop the moving load and prevent it from dropping.

If the control unit receives a move command (UP or DOWN), the corresponding brake is also energised with the motors. A solenoid separates the brake pad and brake disk against the permanently acting spring pressure, and the lifting or lowering movement can be carried out without this braking effect.

When the drive command is terminated (release of the button, emergency stop), the motors and brakes are de-energised (dead man, see above). The brake

magnet loses its effect and the brake springs press the brake pad and brake disk together again. This brings the lifting movement to a standstill.

3.8 Spindle Cover

The spindle is surrounded on three sides by the contour of the column. The side facing the vehicle is open to allow the lifting carriage to move. This side is covered to prevent accidental contact with the spindle and any resulting injuries.

A black strip of fabric foil is stretched between the motor and base plate. This belt is guided through the lifting carriage so that the free area above and below the lifting carriage is permanently covered.

3.9 Overload Protection

The lifting columns are equipped with a weighing function that records the load taken on the basis of the current requirement. If the permissible load on an individual column is exceeded, the control system switches off the entire group and only allows the lowering movement.

If a vehicle is lifted, the suspension springs are relieved before the vehicle is released. It is therefore possible that the overload is only detected after a certain travel distance.

3.10 Overload Protection for Drive Motor

The control board permanently monitors the motor load. If there is an overload of > 15%, the system is automatically switched off. In this case, the lift cannot be raised any further, but can be lowered to the home position.

3.11 Warning and Information Signs

The warning and information signs may not be removed or altered. Defective signs must be replaced.

4 Technical Data

4.1 Overview with Components

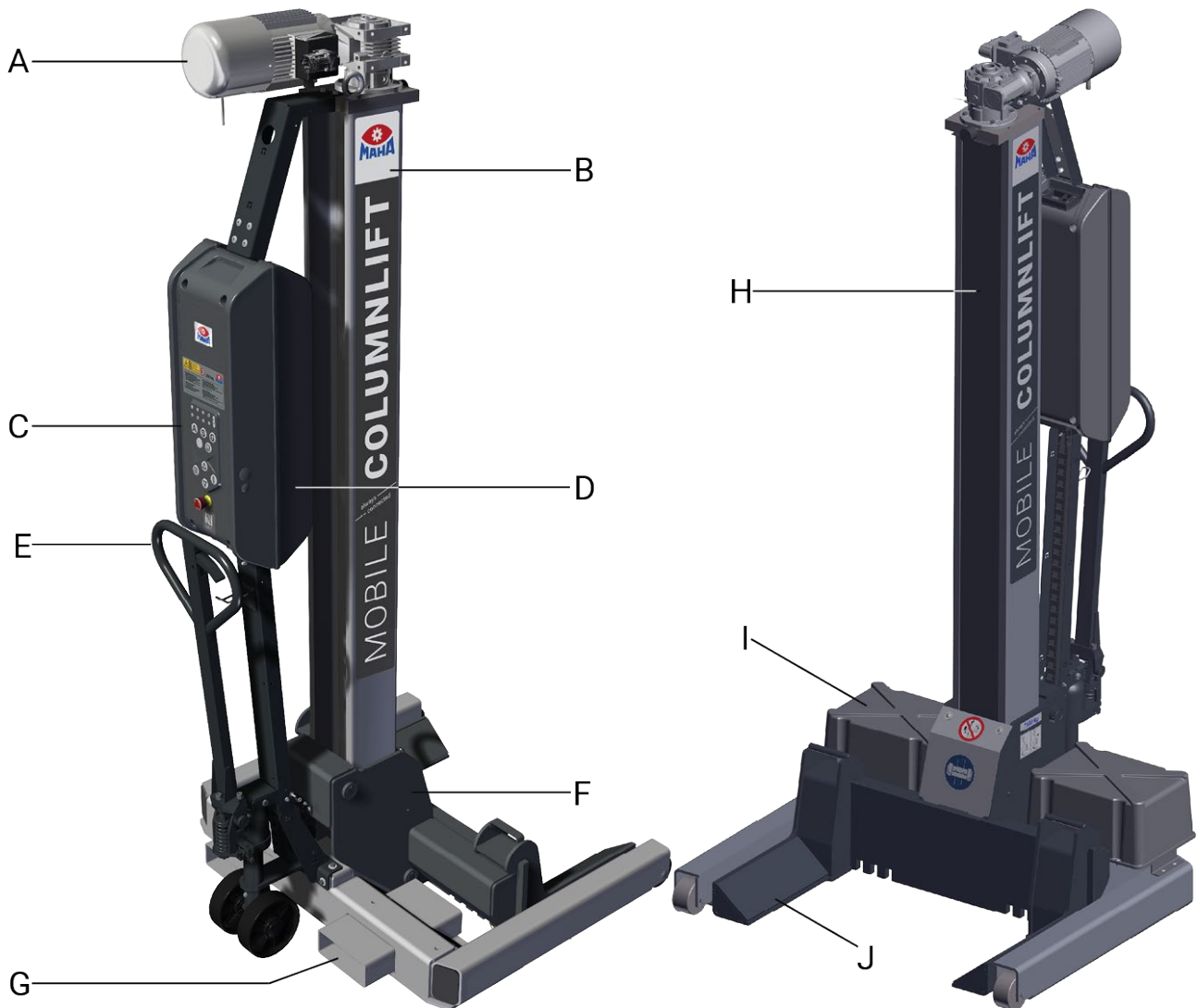

A Gear motor

B Lifting column

C Operating housing with control unit

D Li-ion battery (standard)

E Hydraulic dolly

F Carriage

G Base frame with forklift pockets

H Spindle cover

I AGM battery (option for C_RGA 7.5 UC)

J Wheel fork, adjustable

4.2 Technical Data

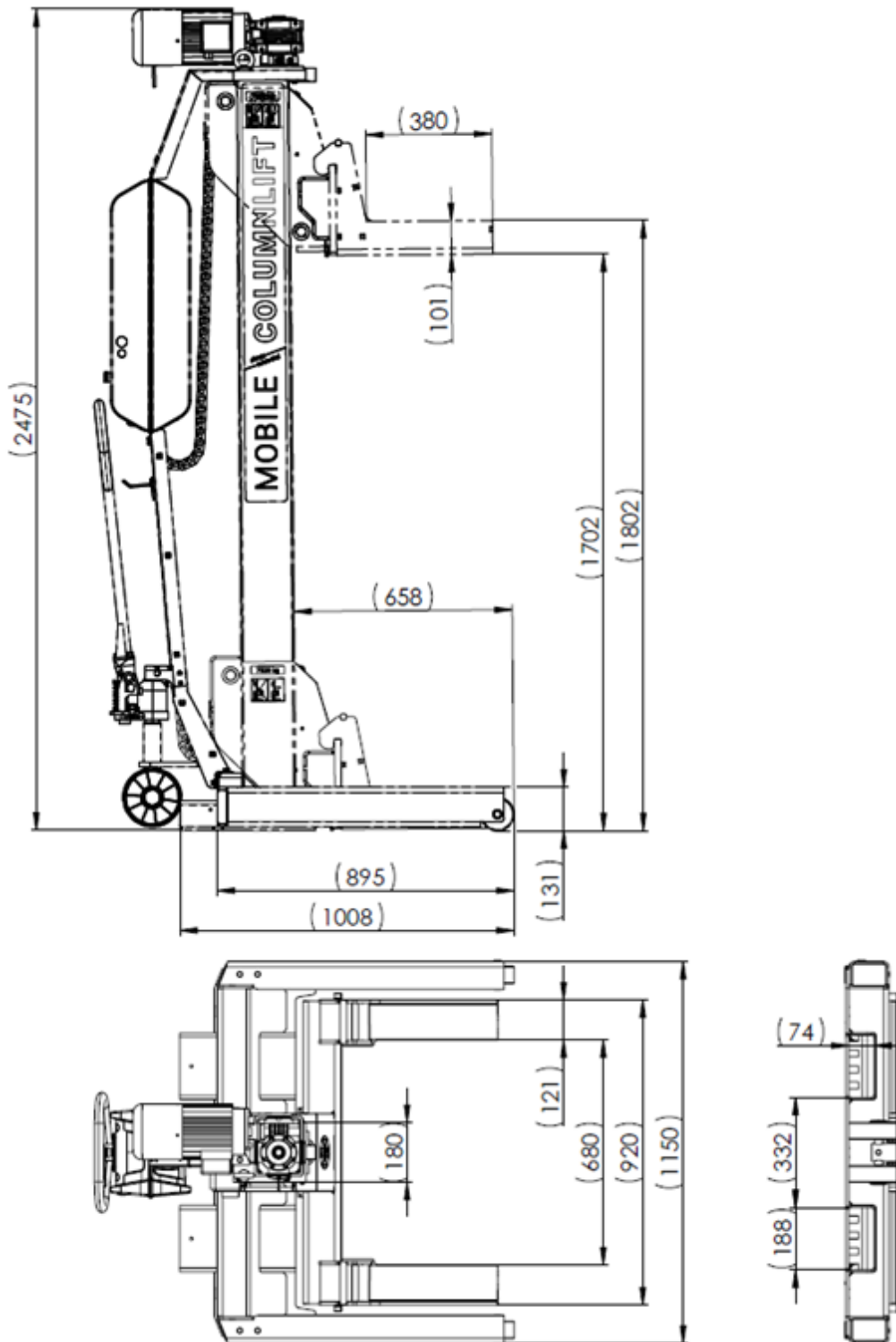

	C_RGA 7.5 UC	C_RGA 8.5 UC
Load capacity per column	7500 kg	8500 kg
Drive power per column	1.5 kW	
Weight per column	525 kg	
Full travel	1700 mm	
Lifting height	1800 mm	
Column profile width	180 mm	
Carriage width	1150 mm	
Carriage height	131 mm	
Overall column height	2474 mm	
Lifting/lowering time	132 s	140 s
Lifting/lowering time High speed (partial load 3500 kg)	85 s	
Inside distance between pick-up forks min. – max.	290...680 mm	
Tyre diameter min. – max.	500...1500 mm	
Length of pick-up forks	380 mm	
Protection class	IP 54	
Noise emission	< 70 dB(A)	
Hertzian pressure on the wheel max.	645 N/mm ²	
Area load on floor slab max.	< 2 N/mm ²	
Power supply of battery	Standard	Li-ion 50.4 V DC
	Option	AGM 4x12 V DC
Voltage for charger	1x 100-230 V AC 50/60 Hz	
Fuse	B 16A RCD (30 mA)	
Lifting cycles Partial load (3500 kg, without high speed)	34	30
Lifting cycles Full load (without high speed)	20	15

4.3 Turning Circle

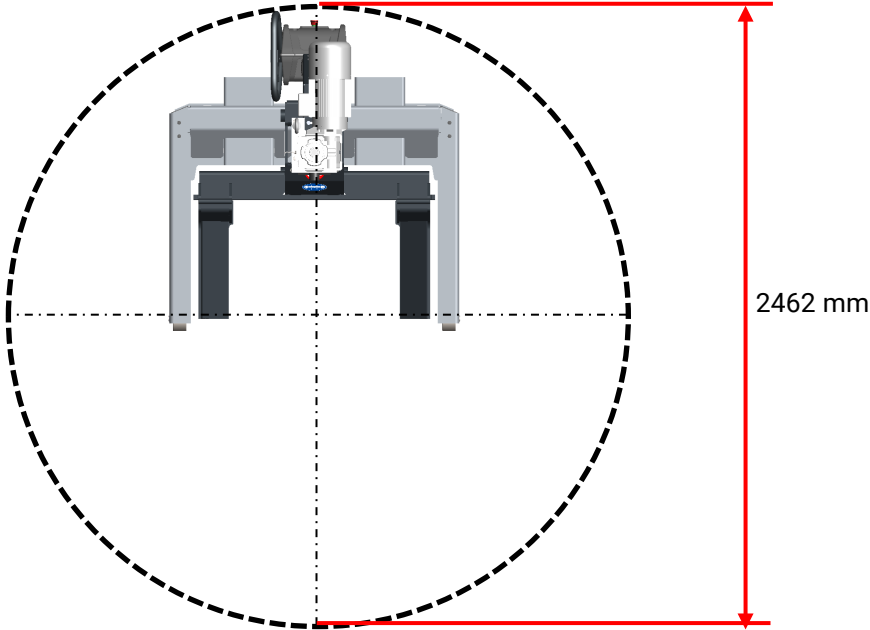

4.4 Danger Zone

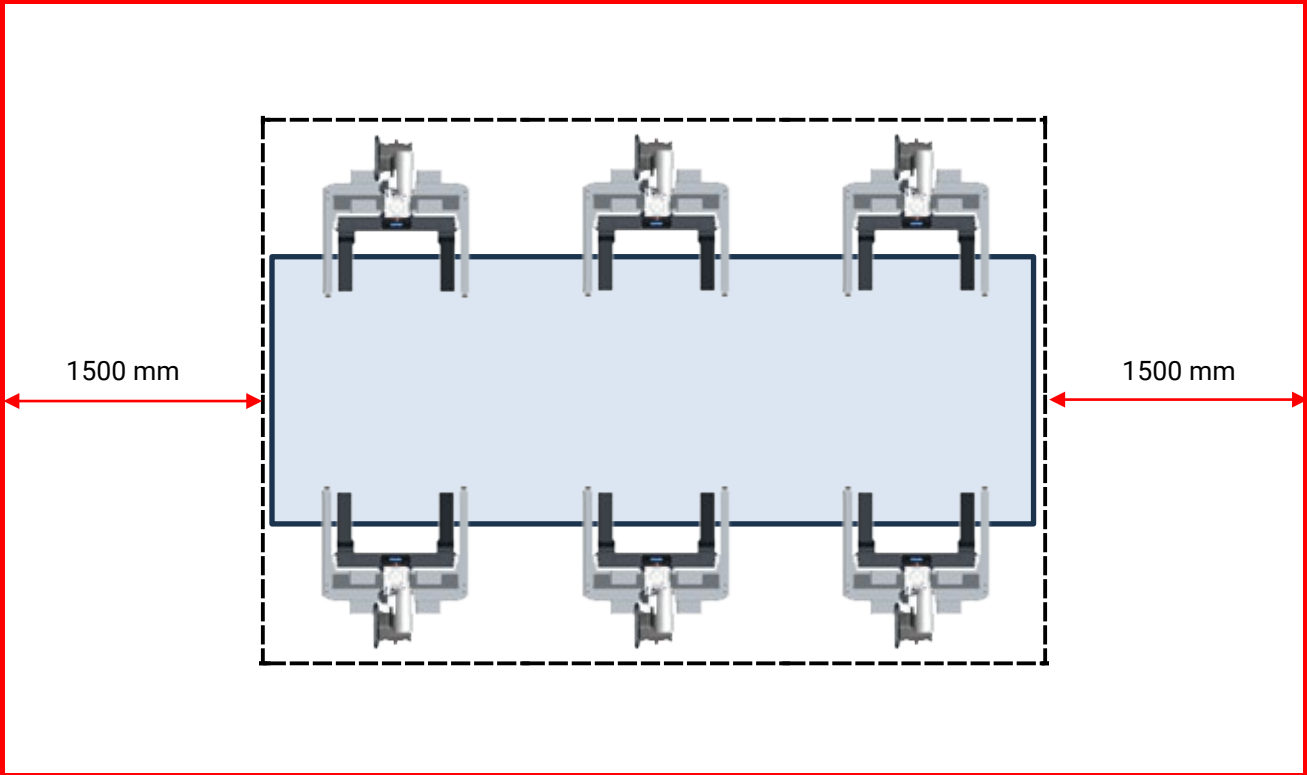

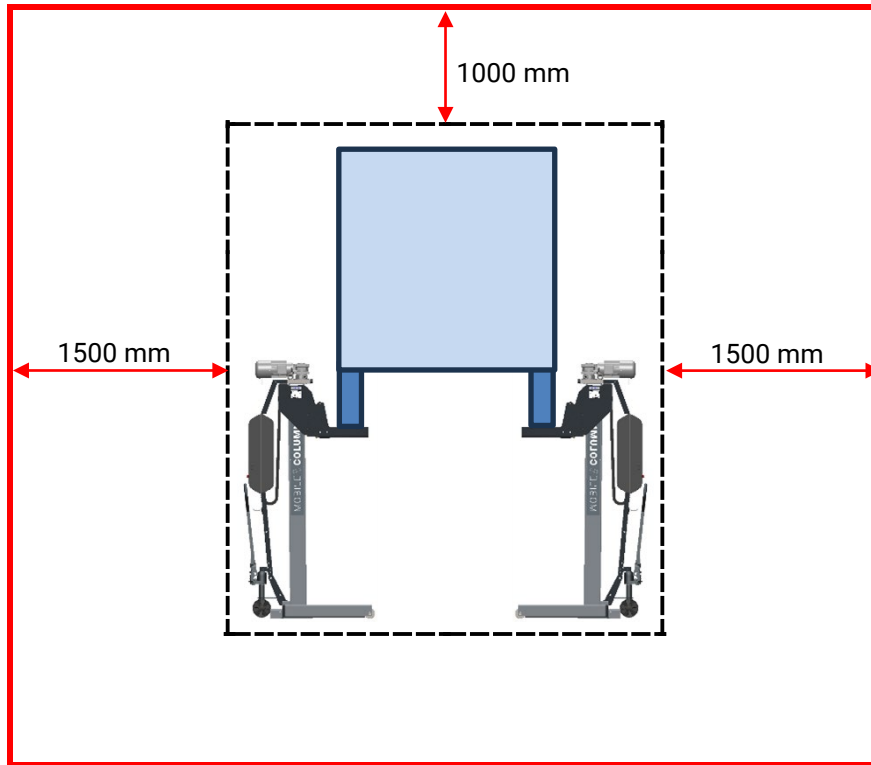

5 Transport, Handling and Storage

5.1 Safety Instructions



WARNING

- Wear personal protective equipment.
 - Standing under a suspended load is prohibited.
 - Before removing the packaging straps, secure the packages against falling and maintain a safe distance. Rebounding packaging straps can cause injuries!
 - Only use lifting equipment and slings that are suitable in terms of type and permitted load capacity.
 - Always ensure that the parts to be transported are suspended or loaded properly and in a fall-proof manner, taking into account their size, weight and centre of gravity. Observe transport regulations.
-

5.2 Scope of Delivery

The lifting columns are delivered upright, either lashed together or individually packed on pallets, depending on the number of pieces and destination.
Content in each case:

- 1 mobile single column with 1 lithium-ion battery
- 1 NFC tag for pairing the lifting columns
- 1 hydraulic trolley
- Operating instructions and other documents
- Transport packaging
- Optional accessories, if applicable

The number of delivered packages and contents must be checked for damage and completeness according to the order confirmation. Any transport damage must be documented immediately and reported to the delivery carrier.

5.3 Packaging Information

Packaging waste must be disposed of in accordance with applicable environmental regulations.

5.3.1 Dimensions and Weight

Dimensions (L x W x H)..... 1280 x 1200 x 2620 mm
Weight approx. 550 kg
(Data valid for pallet packaging)

5.3.2 Centre of Gravity of the Packaged Lift

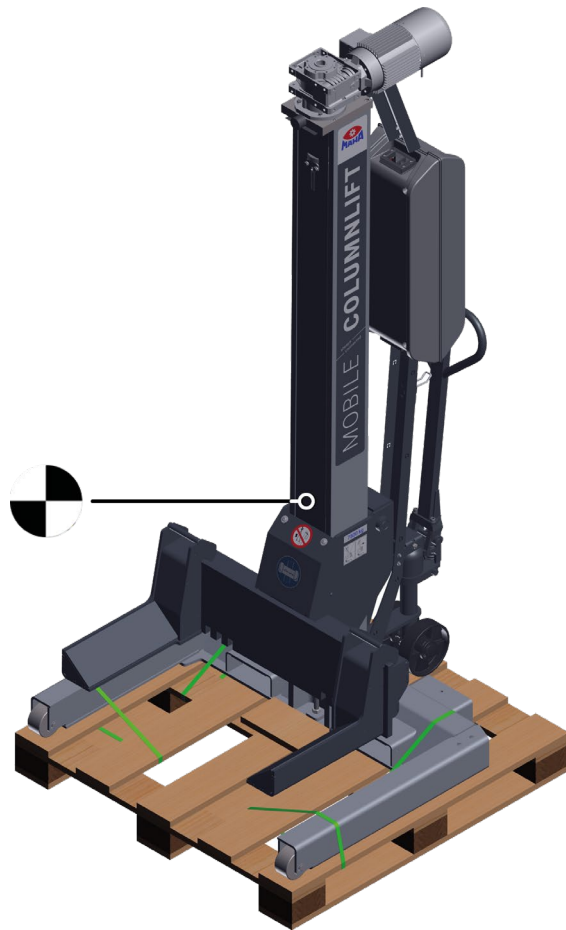

5.4 Transport and Handling

5.4.1 Transport and Handling of the Lifting Columns

To transport the lifting columns, never lift them by the lifting carriage, but by the pallet or by the forklift pockets. For this purpose, the lifting carriage should be approx. 150 mm above the lower end position.

As an alternative to transport by forklift, the eyebolt on the top plate of the lifting column can also be used, e.g. for crane transport of individual columns. The eyebolt must be screwed in tightly.



Transport via forklift pockets ▲

Eyebolt for crane transport ►

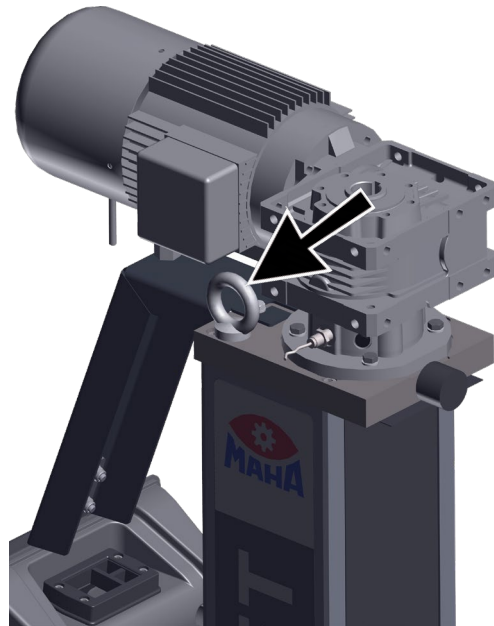

5.4.2 Transport and Handling of the Lithium-Ion Batteries





The lithium-ion battery is mounted in the operating housing of the lifting column at the factory, securely fastened by means of a strap, and wired ready for operation. On delivery, there is a transparent plastic cover over the lifting column or over the operating housing as protection against transport damage and moisture.

In principle, when transporting and handling lithium-ion batteries, strong shocks, impacts (mechanical damage), moisture (rain) and direct sunlight must be avoided, and measures must be taken to ensure safe transport (load securing).

Lithium-ion batteries are assigned the following UN numbers (identification numbers for hazardous substances) during transport:

- UN 3480 – Li-ion battery not in equipment (devices), as spare part
- UN 3481 – Li-ion battery packed in or with equipment (devices)

The following marking is applied ex works for the modes of transport road/rail/sea freight/air freight:

Shipping	Packing	Labelling	Position of labels
As spare part	Single packaging in carton	  	On the cardboard
In the operating housing of the lifting column	Transparent plastic cover over lifting column/ operating housing	 	On the plastic hood

5.5 Storage

5.5.1 Storage of Lifting Columns

The lifting columns must be stored in a covered place protected from direct sunlight. The storage has to take place at a constant air humidity and a temperature between 0 °C and +40 °C. The lifting columns must not be stacked.

5.5.2 Storage and Fire Protection of Lithium-Ion Batteries

For the storage/provision and fire protection of lithium-ion batteries, the relevant national specifications and guidelines as well as the specifications of the fire department and insurers must be observed. Please contact your fire department and/or building insurer in a timely manner.

Storage must be in a well-ventilated, cool place. Safety distance to combustible material min. 2 m.

For the sake of service life, lithium-ion batteries must always be stored in a dry place and within the specified temperature range. In case of longer storage, the state of charge should be checked at intervals of 3...4 months and recharged if necessary.

Only lithium-ion batteries that are in technically perfect condition (no damage, deformation, etc.) may be installed.

6 Installation and Initial Operation

6.1 Safety Instructions



WARNING

- Lifting gear with suitable load handling equipment (hook with safety latch) and chain slings must be used to unload the columns.
 - Downhill wedges must be used with caution to prevent the operator from rolling over or being crushed.
-

6.2 Unloading Lifting Columns

The lifting columns are delivered upright on pallets. The forklift pockets in the base frame or the eyebolts on the top plate can be used to move it to the hall floor.

After unloading, the lifting columns are fully usable – depending on the battery charge status.

6.3 Connecting Lifting Columns Electrically

- A** Input charging cable/
connection cable
- B** Connecting plug for 8+8
columns
- C** Output connection cable

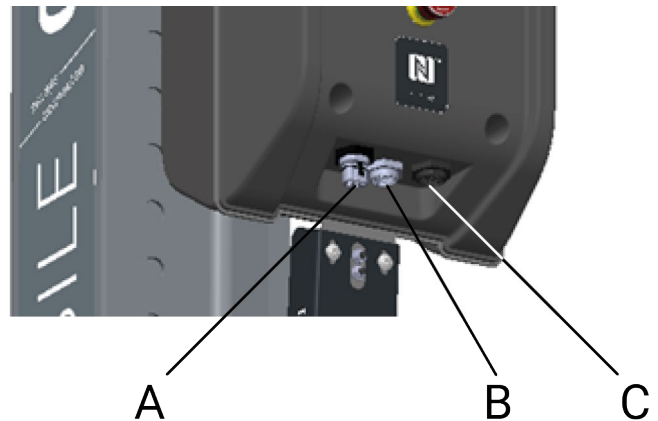

7

Operation



WARNING

- Observe the detailed operating instructions.
- Comply with legal accident prevention regulations.
- Wear personal protective equipment.
- Carry out visual and operational checks daily before the commencement of work (see also section "Inspection and Maintenance Plan").
- Defects must be documented immediately and reported to customer service.
- The permissible load capacity according to the type plate must not be exceeded.
- Only vehicles suitable for the lifting equipment due to their shape and the positioning of their pick-up points may be lifted.
- The wheel forks must be adjusted so that in the event of a tire blowout, the vehicle cannot fall off the lift.
- Operation of the lift is only permissible with mounted and intact protective covers and safety devices.
- Never touch moving parts.
- Never use additional lifting gear for an already raised load.
- Maintain a safe distance from the vehicle and lift in all directions.
- Keep the working area of the load and the lift clear of obstacles. Use a guide if visibility is restricted.
- Vehicle doors must be closed during lifting and lowering.
- The transport of passengers is prohibited.
- Climbing up the lifted vehicle or the lift is prohibited.
- There must not be any people or objects within the safety zone of the lift and the load during the lifting and lowering process.
- Monitor the load and the lift during lifting and lowering. In the event of irregularities, stop the movement immediately or actuate one of the emergency stop switches.
- There is a risk of tripping on floor-mounted load handling attachments.
- Parts must not be placed on the lift or the vehicle to be lifted.
- Keep the lift and the working area clean. **ATTENTION:** Risk of slipping on oily surfaces!
- Protect all parts of the electrical system from moisture.
- Be careful when running vehicle engines. **ATTENTION:** Risk of poisoning!
- Changes to or overriding of the safety features installed is prohibited!
- Structural modifications are generally prohibited and will result in the withdrawal of the operating permit.

- Inching mode should be avoided to prevent the motor from overheating. Instead, drive briskly through.
 - During work breaks and at the end of the working day, the system must be switched off and secured against unauthorised use.
-

7.1 Positioning the Lifting Columns

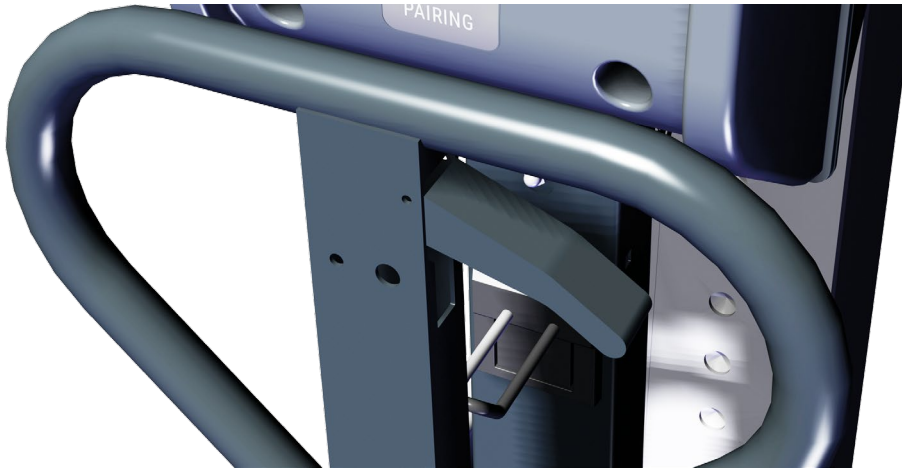

Finger grip on the drawbar of the hydraulic trolley

The lifting columns can be moved and positioned on level, smooth ground by means of a hydraulic trolley with drawbar. The hydraulic trolley with drawbar works like a pallet truck.

The finger grip has three possible positions (see figure):

- To lift, move the finger grip to the lower position and pump with the drawbar to the desired height.
- To lower, pull the finger grip upwards.



CAUTION

When lowering, make sure no body parts or objects are under the lifting column!

- To move the lifting column, move the finger grip to the centre position.

7.2 Adjusting the Vehicle Support



WARNING

Avoid uneven load distribution. Danger of tipping! After adjustment, replace and secure the hinged cotter pin.

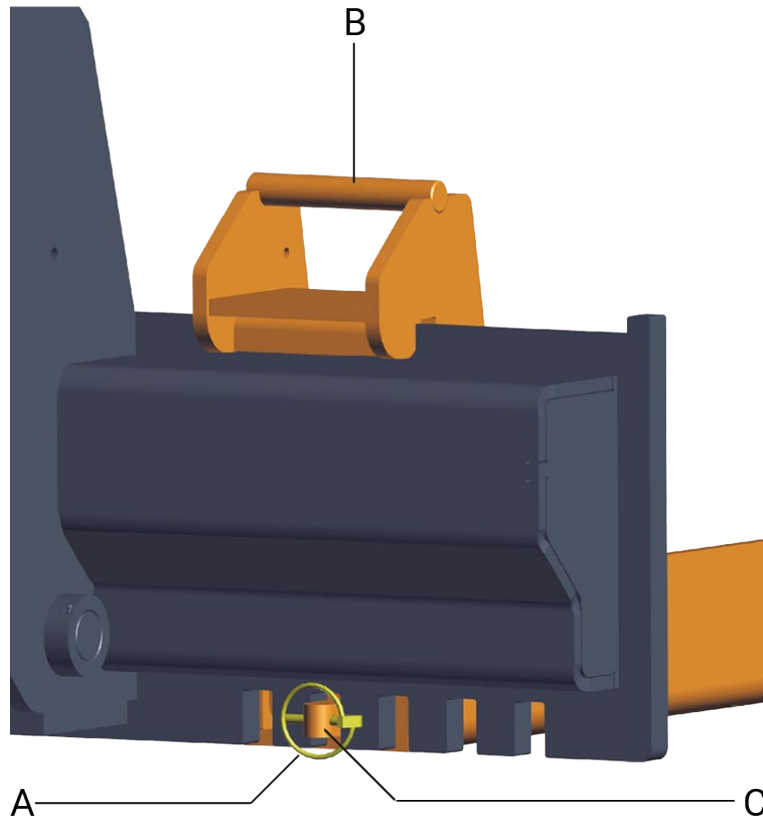

- 1 Pull off the hinged cotter pin (A) for unlocking.
- 2 Tilt the wheel fork at the handle (B) and front end and position it in the desired notch using the locking pin (C).
- 3 Secure again with hinged cotter pin. Check the secure fit of the wheel forks.
- 4 Repeat the procedure for the second wheel fork. The wheel forks must always be positioned symmetrically to the lifting column to ensure even load distribution!

When using wheel forks, their clear width can be adjusted.

To prevent the wheel from falling through in the event of a tyre blowout, the rim diameter (a) must always be clearly larger than the clear fork width (b) (see Illustration)!

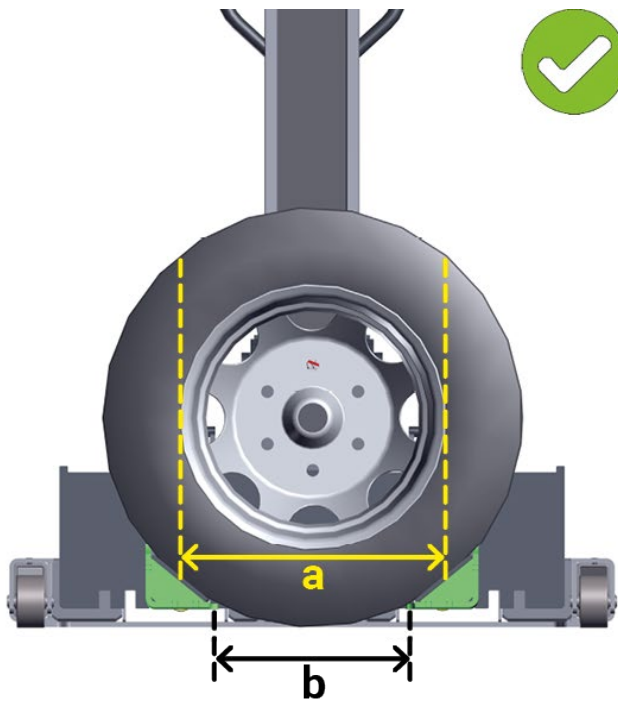

Wheel forks correctly adjusted: $a > b$

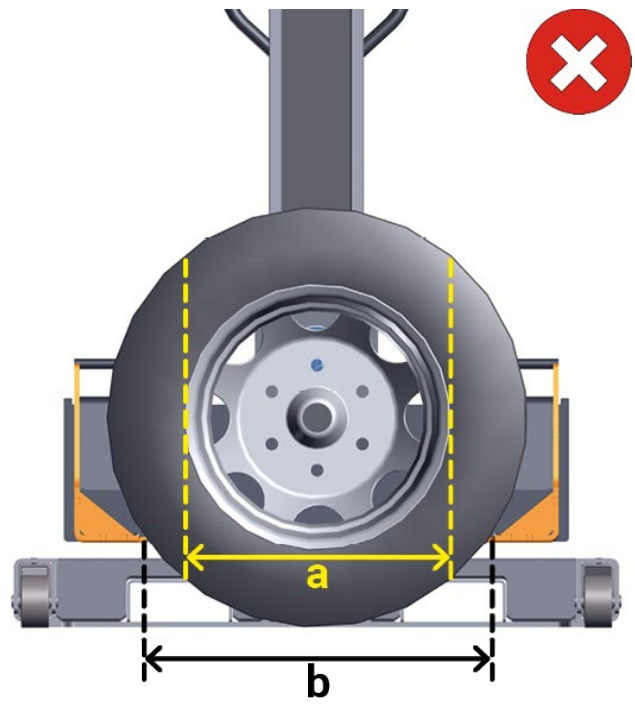

Wheel forks adjusted too far: $b > a$

7.3 Picking up a Vehicle



WARNING

Before lifting a vehicle, make absolutely sure that there are no objects under the contact surface of the lifting column. Danger of tipping!

Push the vehicle supports of the individual lifting columns all the way to the stop under the wheels or mounting points of the vehicle to be lifted.

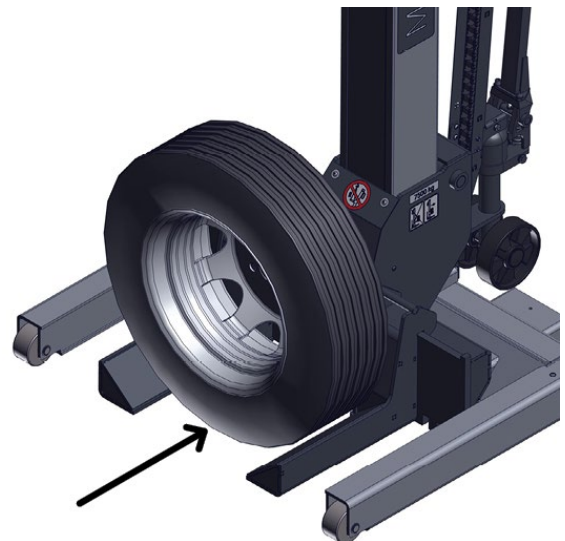

7.4 Controls and Indicators

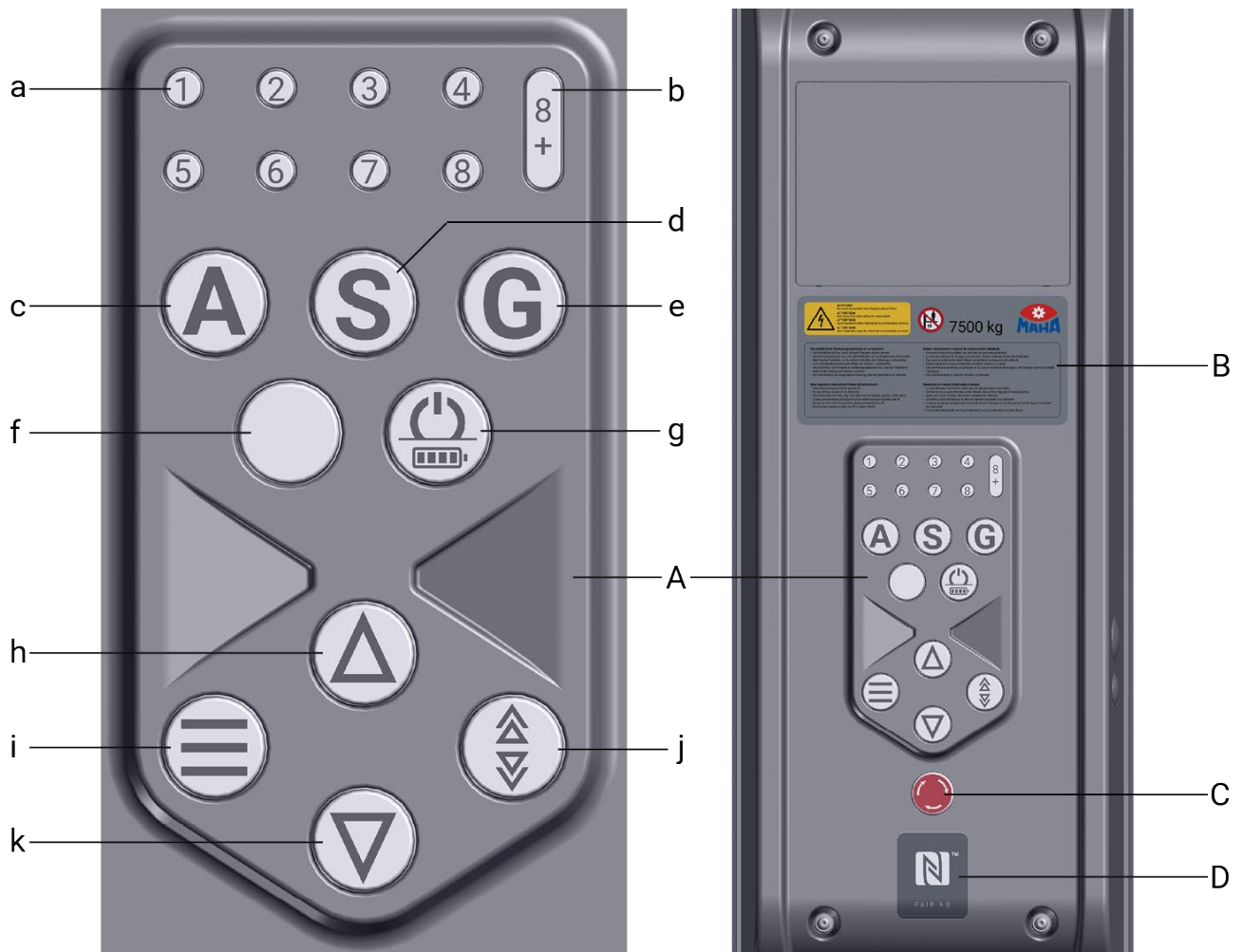

A Control panel

a Lifting column lamps 1...8

b Lifting column lamp 8+

c ALL button

d SINGLE button

e GROUP button

f ERROR lamp

g ON/OFF button

h UP button

i FUNC button

j SPEED button

k DOWN button

B Short operating instructions

C Emergency stop pushbutton

D NFC sensor field

7.5 Switching on

To switch on a column, press the ON/OFF button briefly. This is followed by a self-test during which all lamps light up briefly and the signal generator sounds briefly. The ON/OFF button lights up continuously.



If the lifting columns are switched on when the emergency stop button is pressed, an error code is output (see section "Troubleshooting > Error Codes").

7.6 Login Process (Pairing)



Pairing of the lifting columns via NFC tag and sensor field

7.6.1 Login Lifting Column

To put an individual lifting column into operation after switching it on, the NFC tag must be held against the sensor field twice at short intervals. After the first time, the signal generator sounds once briefly and the lifting column lamp 1 lights up. With repeated confirmation by the NFC tag, the beeper sounds again, the ALL button lights up and the UP and/or DOWN button lights up blue. The column is ready for operation.

7.6.2 Connect Lifting Columns to Form a Network

In order to connect the lifting columns into a network (min. 1 to max. 8 columns) after switching on, the selected columns must be preselected **once** in succession with the NFC tag after switching on.

To close the connection, the NFC tag is held once again against the sensor field of the last column added. The signal generator confirms this by beeping briefly twice. The network is now closed. To add another column to the network, the network must be opened and reassembled.

The lifting column lamps indicate which lifting columns are active by lighting up. The digits 1 to 8 are arranged in the order of pairing.



The first lifting column that has been paired is assigned the number 1, the second the number 2, and so on. It is therefore recommended that when pairing, the lifting columns are included in the network in sequence so that it is easy to identify which lifting column is in which position of the vehicle to be lifted.

IMPORTANT: It must be ensured that only the columns that are to be used on the vehicle are grouped together.

7.6.3 Cancel Login Process



WARNING

When not in use or **before** transferring to another vehicle, an existing network must be released by pressing the ON/OFF button!

During the login process, data is stored on the NFC tag and in the paired columns, which must be deleted when the login process is cancelled. It is essential to close the network first. Pressing and holding the ON/OFF button reopens the network and deletes the data in the paired lifting columns.

7.6.4 Error in a Column during Pairing

If there is an error in a lifting column, it cannot be included in a network. When trying to pair with the NFC tag, 5 beeps are emitted and pairing is denied. In order to be able to connect this lifting column, the error must first be rectified.

7.7 Lifting and Lowering

The UP or DOWN button is used to move the lift. If one or both buttons light up blue, you can move in the respective direction.

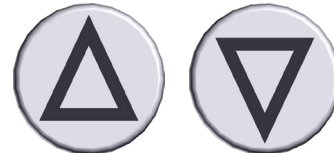

If both buttons are not illuminated, either the system cannot be moved at all or it is currently being operated from another lifting column. In the network, only one column can be operated at a time.

7.7.1 Driving up to an Obstacle

If an obstacle is unexpectedly encountered during lowering, the control system interrupts the lowering process.

The DOWN button is no longer lit and the UP button flashes briefly repeatedly. On the other lifting columns in the network, the DOWN button is also not illuminated and the UP button is continuously illuminated.

To free the carriage, it must be moved upwards until the DOWN buttons on all lifting columns light up again.

7.7.2 CE Stop

The CE stop is preset at the factory.

When lowering the lifting columns, the lowering movement is stopped as soon as one lifting carriage in the network has reached the CE stop height. At the same time, the beeper sounds once.

Pressing the DOWN button again causes the lifting carriages to move further

down. The signal generator sounds continuously while lowering as long as the column with the lowest lifting height is within the CE stop area.

7.8 Radio Standby

Radio standby is switched off on delivery.

If there is no action on the lift control for 5 minutes, the lifting column network switches to "Radio standby" mode and releases the radio channel used. Every 4 seconds, the lamps or control button lamps that were lit up until then flash briefly.

If a button of a column is pressed in Radio standby, the signal generator sounds as long as the button is pressed. To exit Radio standby, the ON/OFF button must be pressed briefly. Then the lamps flash quickly while the controller searches for a free radio channel. As soon as the lamps light up continuously, the lifting column network is ready for operation again.

7.9 ALL Operating Mode

In the ALL operating mode, the entire system, i.e. all lifting columns together, is always moved with the UP or DOWN button. All lifting column lamps of the columns in the network are permanently lit.



If the <A> button flashes on a column in the network, the network cannot be operated. Normally, there is then an error, or at least one lifting column is in SINGLE or GROUP operating mode.

7.10 SINGLE Operating Mode

To be able to move certain lifting columns of the closed system individually, e.g. to free a single wheel or to readjust it, the SINGLE operating mode can be activated on the desired lifting columns. Several lifting columns of a network can also be in SINGLE operating mode at the same time.



IMPORTANT: It must be ensured that the lifted load does not become unstable.

To activate the SINGLE operating mode on a column, press the SINGLE button <S>. The beeper sounds once. Then confirm the selection within 10 seconds with the NFC tag on the sensor field. The beeper sounds twice and the <S> button starts to light up. Now this lifting column can be moved UP or DOWN individually. All other lifting columns in the network can no longer be operated unless they are also in SINGLE operating mode.

If the SINGLE operating mode is not confirmed with the NFC tag within the 10-second time window, then the relevant column switches back to the last active operating mode.

To exit the SINGLE operating mode, press the ALL button <A>. At the same time, the beeper sounds once and the <A> button starts to light up.

If at least one lifting column of the network is in the error state, the operating mode cannot be changed to SINGLE. No movement is possible!

7.11 GROUP Operating Mode

A group can be formed in order to remove several lifting columns from a network and to be able to move them together, e.g. for the installation and removal of vehicle axles. A group consists of a minimum of one lifting column, in practice several lifting columns.



To do this, press the <G> GROUP button on the desired lifting column. The beeper sounds once. Afterwards, this selection must be confirmed within 10 seconds with an NFC tag. At the same time, the beeper sounds twice and the <G> button starts to light up. The GROUP operating mode is now activated on this lifting column.

If the changeover is not confirmed with the NFC tag, then the previously active operating mode is restored.

To integrate further lifting columns into this group, repeat the same procedure on the desired lifting columns of the same network.

While the GROUP operating mode is active, the overall network cannot be moved. If at least one lifting column of this network is in SINGLE operating mode, the group cannot be moved either.

In GROUP operating mode, only the lifting column lamps of the lifting columns that are in the group are lit. All other lifting column lamps flash.

If all lamps of the lifting columns in the group are flashing, then one or more lifting columns are in the SINGLE operating mode.

Deactivate group mode or remove lifting columns from the group:

Press ALL button <A>, the beeper sounds once. This lifting column is thus excluded from the group.

To exit the GROUP operating mode, all associated lifting columns must be excluded from the group in the same way. As soon as all lifting columns are back in ALL operating mode, the entire system can be moved again.

7.12 Fast Travel (SPEED)

The SPEED button can be used to move the lifting column network or individual lifting columns at a higher speed. To activate fast travel, the SPEED button must be held down while pressing the UP or DOWN button at the same time. This is also possible during the travel movement. The SPEED button starts to light up.



If the SPEED button is released during the process, the process continues at normal speed.

The travel speed when fast travel is activated depends on the loading condition of the lifting column.

Fast travel can be terminated by releasing the SPEED button or the UP/DOWN buttons.

Fast travel is not possible if

- the lifting column is not yet referenced;
- no weight is known at the beginning of the lowering process.

7.13 Switch off / Open Network

The lifting column is switched off by pressing the ON/OFF button for longer than 4 seconds. When switching off, all lamps go out and a possibly existing network is released.



When switching on again, the network must be re-paired and closed.

While the charging cables are connected, the lifting columns cannot be switched off, or they switch on again automatically immediately.

The lifting column control is switched off in two stages:

Stage 1 – After approx. 2 seconds, an existing network is opened.

Stage 2 – After another approx. 1.5 seconds, the lifting column control is switched off completely.

If the lifting columns are to be paired again, release the ON/OFF button after releasing the pair and start pairing.

When the network is open, all lifting columns switch off automatically after approx. 10 minutes if no charging cable is connected.

7.14 Radio Communication

Radio communication is the default communication interface and is automatically activated when the network is closed, unless a cable network has been formed.

Radio communication can be disturbed by radio transmitters that transmit in the similar frequency range, such as WiFi or other lifting column networks. If this is the case, a new free radio channel can be searched for manually (see section “Search New Radio Channel”) or a cable link can be established (see section “Cable Emergency Operation”).

If a radio interruption is detected, the error "Radio connection" is output. At the same time, the error lamp flashes the error code "Radio error". The green lifting column lamps start to flash. The lifting column number with the slowly flashing lamp is the lifting column that has detected the error. The fast flashing lamps indicate the lifting column numbers to which the communication of this lifting column is disturbed.

While the "Radio error" code is output, the lifting column control unit attempts to find a free radio channel at intervals of approx. 20 seconds. The signal generator always sounds briefly to indicate that a new radio channel is currently being tested. If a suitable radio channel has been found, it is automatically set on all lifting column controls and the error is then deleted.

Continued operation of the lifting column is possible again as soon as a suitable radio channel has been found. Otherwise, it is recommended to establish a new interconnection with the cable emergency operation.

If the battery is discharged or there is a defect, this lifting column cannot be reintegrated into the network. The network must then be opened at all lifting columns and a new network formed.

7.15 Search New Radio Channel

If radio problems occur frequently, radio communication can be improved by searching for a new, free radio channel. To do this, press the SINGLE <S> button for 3 seconds.



Afterwards, the best available radio channel is searched for in the course of approx. 20 seconds and automatically set at all lifting columns of this network. During this time, the illuminated operating buttons flash as in Radio standby. As soon as a new radio channel is set, all operating buttons light up. Moving the lifting columns is now possible again.

7.15.1 Communication Error (Radio or Cable Error)

If columns are interconnected, the preferred communication among columns is radio.

In the lifting column controllers that detect a communication error (radio or cable error), the lifting column lamps of those lifting columns whose data are faulty or missing flash rapidly.

For controllers that detect an error on another lifting column, all lifting column lamps flash.

For the lifting column with the error (except for radio or cable error), the associated lifting column number flashes.

If there is a radio or cable error, all lifting column lamps of the affected lifting columns flash rapidly. In case of other errors, only the lamp with the assigned number flashes on the lifting column where the error occurred.

7.15.2 Overview: Status of the Lifting Column Lamps

Status	Description
	Lifting column is not active/not in the network.
Dark	In the case of the lifting column with the error, only the associated lifting column number is illuminated, all other lifting column numbers are dark. Error lamp flashes. Exception: Communication error; here the lifting column numbers with the communication errors flash quickly.
Lights	Lifting column is active. Lifting column can be moved.
Flashes slowly every second	Lifting column has been paired and is waiting for the network to be closed. Lifting column with error (error lamp also flashes).
Flashes quickly at 0.5-second intervals	Lifting column cannot be moved because SINGLE or GROUP operating mode is active. Communication channel of the lifting column with error or defect. Communication can be via cable or radio.

7.16 Cable Emergency Operation

Cable emergency operation is to be used if, for example, there is a poor radio connection with radio interruptions.

Only one cable group can be formed at a time with the same charging cable connection.

When creating additional cable networks, each must have its own charging cable connection.

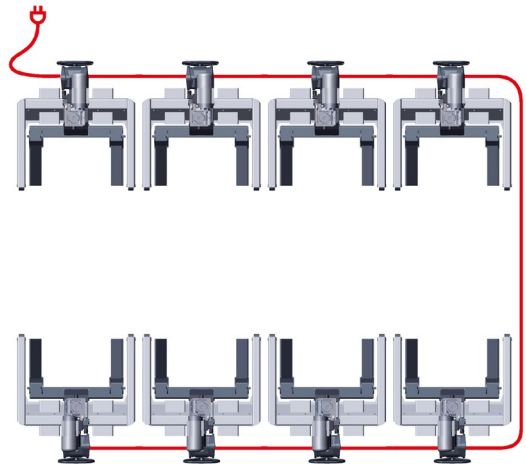

7.16.1 Activate Cable Emergency Operation

The following steps must be performed in the specified order to activate the cable emergency mode:

- 1 Open the existing network with the ON/OFF button.
 - 2 Switch off all lifting columns of the cable network to be created with the ON/OFF button.
 - 3 Connect all lifting columns of the cable network to be created with the charging cable.
 - 4 Switch on all lifting columns of the cable network to be created with the ON/OFF button.
 - 5 Perform pairing process with the NFC tag.
 - 6 Close the cable network with the NFC tag.
- The lifting columns are ready for operation.

7.16.2 End Cable Emergency Operation

The following steps must be performed in the specified order to end the cable emergency operation:

- 1 Open the existing cable network with the ON/OFF button.
 - 2 Switch off all lifting columns of the cable network with the ON/OFF button.
 - 3 Remove all charging cables.
- The lifting columns are ready to set up a new radio-controlled network.

7.17 Output Software Version Identifier

If the ON/OFF button is pressed for a long time when the lifting column is switched on, a flash code is output which can be used to identify the installed software version. After switching on, the beeper sounds 4 times and the error lamp is switched on.



After that, the ON/OFF button starts to output the flash code in blue. When the ON/OFF button is released, the output of the flash code is also stopped and the self-test of the lamps starts.

To output the flash code again, the lifting column must first be switched off. Then proceed again as described above.

7.18 Charge Battery

NOTICE

Early charging – when the lamp colour changes from green to yellow - can extend the battery life.

The lamp colour of the ON/OFF button indicates the current battery charge level.



GREEN

Battery has enough capacity.



YELLOW

Few lifting cycles possible, charging recommended.



RED

Battery must be charged.

The discharge process is not abrupt, but is noticeable by a gradual slowing down of the lifting and lowering movements.

When the battery is discharged, an error code is issued. To acknowledge the error, the emergency stop pushbutton must be actuated and unlocked again. In this situation, the lifting columns can only be lowered.

For charging, the lifting columns must be connected to the mains supply by means of charging cables. When connected, the lifting columns are automatically switched on. During charging or as long as the mains supply is connected, the lamp of the ON/OFF button flashes and the lifting column cannot be switched off.

Procedure:

- 1 Connect the first lifting column to the mains supply via charging cable.
 - 2 Connect the second lifting column to the first lifting column via charging cable.
 - 3 Connect all other lifting columns *one after the other* via charging cable.
- The battery of the respective lifting column is fully charged when the lamp of the ON/OFF button lights up green continuously.

8 Troubleshooting

If an error occurs, the error lamp lights up or flashes. It is then no longer possible to move the lifting column network or the lifting column.

The number of flash cycles of the error lamp gives the error code (see section "Error Codes").

By pressing the FUNC button, the flash code output in progress can be terminated and immediately started from the beginning. This enables fast counting of the flash code without unnecessary waiting time.

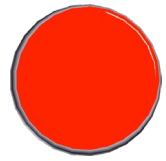

8.1 Diagnostics

- a. Is only one number lamp of the network flashing on the lifting column?
 - ▶ This is the lifting column with the operating error.
- b. Are all the number lamps of the network flashing on the lifting column?
 - ▶ The error has occurred on another lifting column. The error lamp flashes once, indicating that the error has occurred on another lifting column. There is no error on the lifting column in question, but it cannot be moved because another lifting column has an error.
- c. Are number lamps (one or more) of the network flashing rapidly?
 - ▶ Communication error (radio, cable). The number lamps from which faulty data sets are received or which do not send any data sets flash quickly.

8.2 Error Codes

Flash code	NFC code	Description	Subcode	Remedy
1	E001	Error on other lifting column		Search for faulty lifting column.
2	E002	Emergency stop actuated		Unlock emergency stop, press several times.
3	E003	Radio error	1 = Radio protocol 2 = Radio module	Establish cable connection.
4	E004	Cable connection error		Check cable and plug connections.
5	E005	Sluggish movement; motor power too high		Reduce load, lubricate recirculating ball nut.
6	E006	Battery discharged/undervoltage		Charge batteries.
7	E007	Motor temperature too high, line to temperature sensor interrupted		Wait until motor has cooled down. Contact service team.
8	E008	Height difference too large		In SINGLE operating mode, align the lifting column.

Flash code	NFC code	Description	Subcode	Remedy
9	E009	Output stage overcurrent/short circuit		Contact service team.
10	E010	Speed sensor	1 = Short circuit 2 = Cable break	Contact service team.
11	E011	Sensor lifting column bottom	1 = Short circuit 2 = Cable break	Contact service team.
12	E012	Safety switch	1 = Short circuit 2 = Cable break	Contact service team.
13	E013	Load pickup sensor	1 = Short circuit 2 = Cable break	Contact service team.
14	E014	Nut break		Contact service team.
15	E015	Latch	1 = Current too high 2 = Current too low	Contact service team.
16	E016	Motor brake	1 = Current too high 2 = Current too low	Contact service team.
17	E017	Brake chopper		Contact service team.
18	E018	Spindle or motor speed out of tolerance		Contact service team.
19	E019	Overvoltage in the DC link		Contact service team.
20	E020	Voltage 12 V		Contact service team.
21	E021	Keypad error		A button is pressed when switching on or closing the network. Check, contact service.

9 Inspection and Maintenance

Depending on the operating conditions, the lift must be inspected at intervals of no more than 12 months. In particular, safety equipment, fastenings and load-bearing components must be inspected.

This inspection must be carried out by a competent person in order to ensure safe operation until the next inspection.

The inspection and its findings must be documented. MAHA provides the document "Inspection of lifts" for this purpose, which should preferably be filed in the inspection logbook. This list of test points is based on the DGUV 308-002 applicable in Germany and is adapted to MAHA lifts.

All tests must be carried out with the system unloaded!

9.1 Daily Checks before Starting Work

To ensure the safety of the system during operation, the following visual and functional checks must be carried out daily before starting work or beginning a shift.

9.1.1 Cables and Actuating Elements

Cables must not have any visible damage. Cables with visible pinch points, damaged sheathing or kinks must be replaced with new ones immediately.

Buttons must be smooth-running and clean and must not be damaged. Activated buttons must return to their initial position immediately after being released.

A lifting system with damaged cables or actuating elements must not be operated.

9.1.2 Emergency Stop

The emergency stop shuts down the drives of the lifting system in order to bring the system to a safe state.

To test, trigger a lifting movement by pressing a button after switching on the control unit. Press the emergency stop button when the UP button is pressed. The movement of the system must come to an immediate standstill.

The test must be repeated for all operating points with emergency stop. A system with a defective emergency stop must not be put into operation.

9.1.3 Illumination of the Control Unit

The illumination of the operating and display elements shows error codes, operating statuses, number of connected columns and much more.

To check, observe the control unit with all operating and display elements when switching on the lift. These must light up 3 times in succession.

A system with defective lighting must not be put into operation.

9.1.4 Locking the Adjustable Wheel Fork

The wheel forks have a locking pin with a lynch pin for positioning on the lifting carriage.

The locking pin and lynch pin must not be damaged. If the wheel fork is positioned in the lifting carriage, check that the wheel fork cannot be lifted out due to the inserted lynch pin.

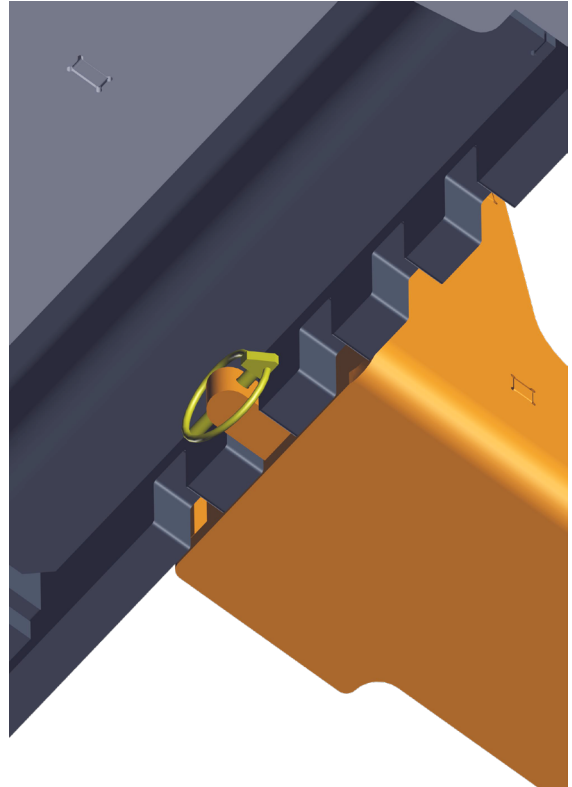

9.1.5 Hydraulic Dolly

The hydraulic dolly is used to position the lifting column. It is driven by a manually operated hydraulic pump.

The inspection consists of a visual check of the hydraulic pump (A) for oil leakage and the plastic wheels (B) for damage.

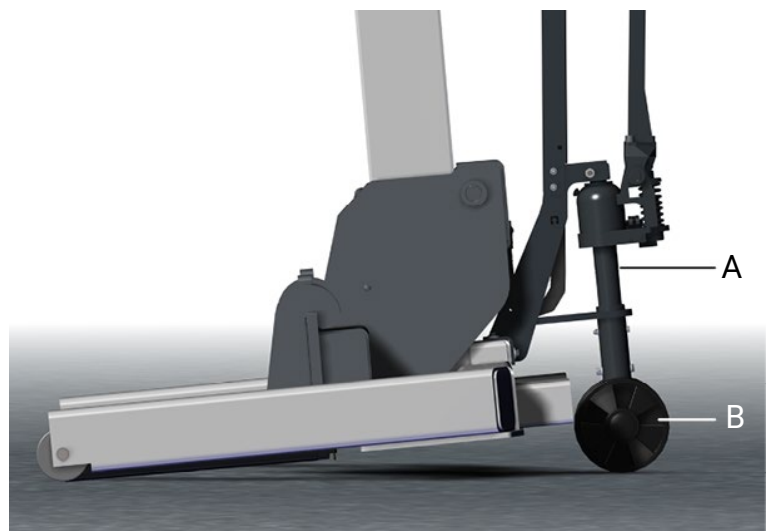

9.1.6 Load Handling Attachments

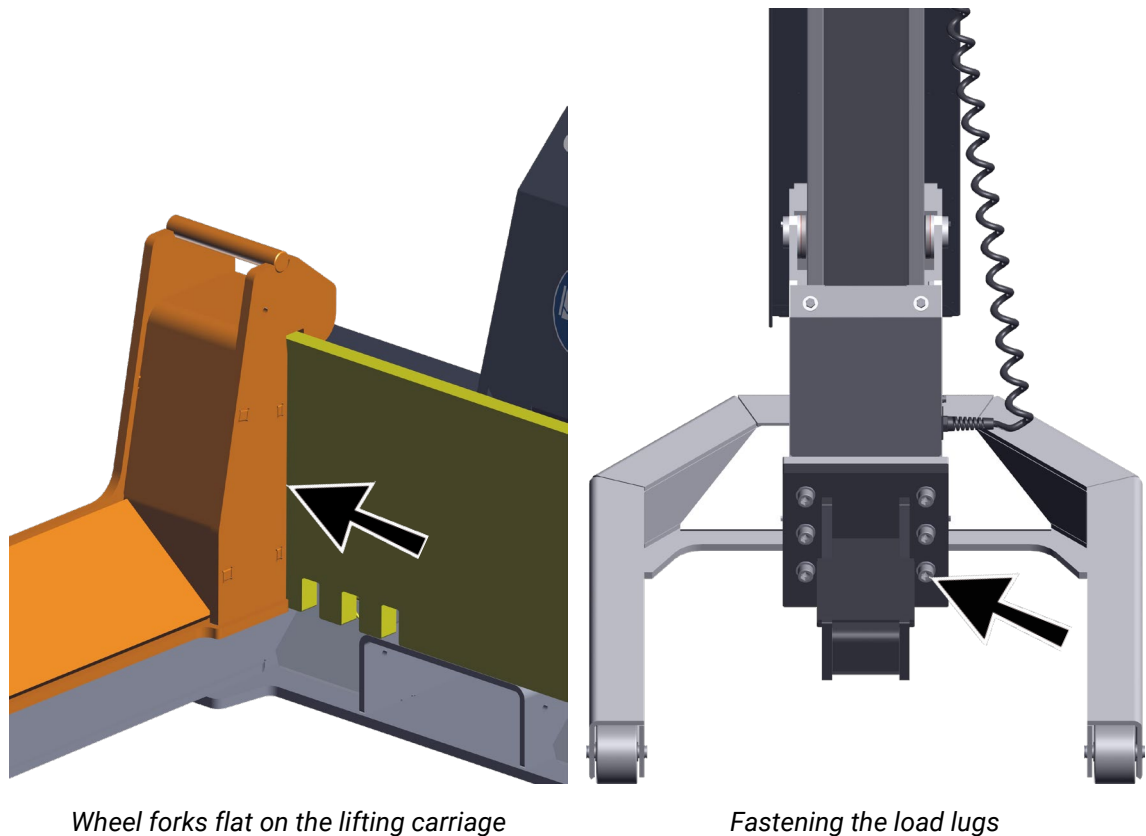

Wheel forks flat on the lifting carriage

Fastening the load lugs

Load handling attachments such as wheel forks or customised load lugs (with flanged lifting carriages) must be checked for damage such as deformation, cracks, corrosion and soiling. Damaged load handling attachments must be replaced.

Wheel Forks

Check the locking pins for correct engagement. This is the case when the wheel forks lie flat against the front plate of the lifting carriage (see Illustration). In addition, check that both wheel forks are positioned symmetrically around the lifting column.

Load Lugs and Flanged Lifting Carriages

Check load handling attachments for correct attachment. Pay attention to the screw connection (see Illustration). For tightening torque, see section “Yearly Inspection”.

9.2 Six-Monthly Inspection

9.2.1 Spindles and Support Nuts

Spindles and support nuts must be visually inspected for damage and dirt. These lead to increased wear and premature failure of the support nut.

Damaged support nuts may no longer have the full load-bearing capacity (due to chipping, cracks). Particular attention must be paid to the closed deflections of the ball screw nut.

If the support nut or spindle is damaged, the entire ball screw drive must be replaced!

9.2.2 Running surfaces and Flange Rollers

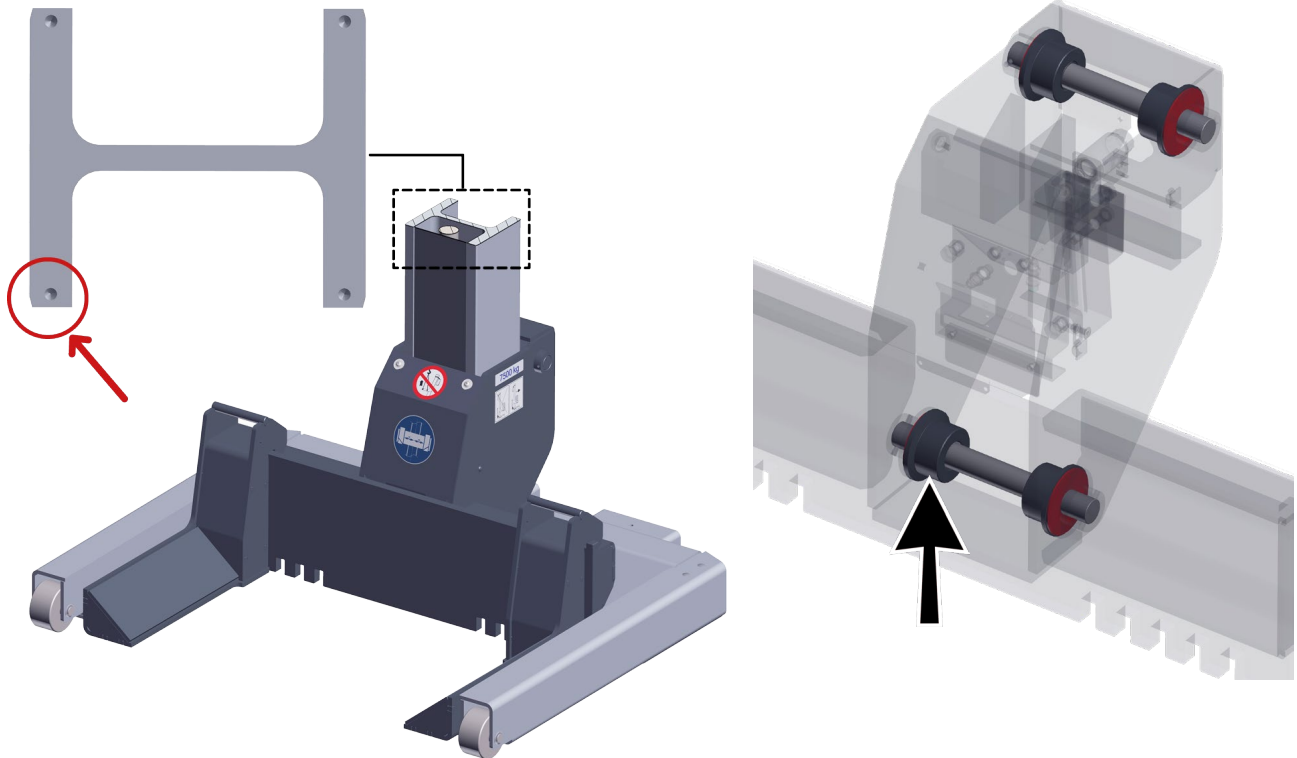

The running surfaces and flange rollers on which the lifting carriage is moved must be visually inspected for damage, corrosion and soiling. If necessary, clean the running surfaces and apply a thin film of oil or grease.

Damaged flanged rollers must always be replaced axle by axle, including axle and thrust washer.

9.2.3 Thrust Washers

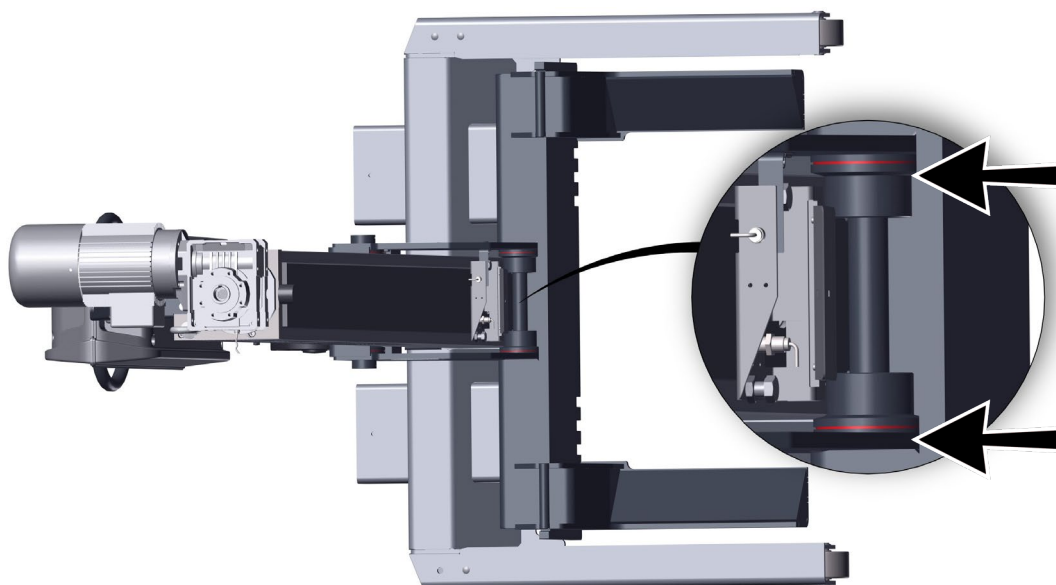

The inspection is carried out using visual check and a feeler gauge. Check the bronze thrust washers (see Illustration) for wear using a feeler gauge. The thickness of a thrust washer when new is 2 mm. If the wear on an individual thrust washer exceeds 1 mm, it must be replaced.

9.2.4 Wear Test on Flange Rollers and Column

In addition to the visual check, the wear of the flange rollers on the lifting carriage must be tested. To do this, hold the lifting carriage by the pick-up fork, pull firmly forwards and twist, see illustrations.

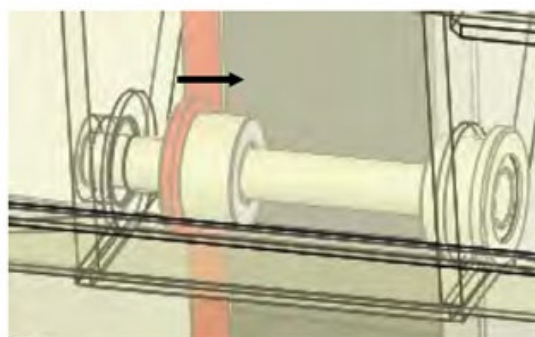
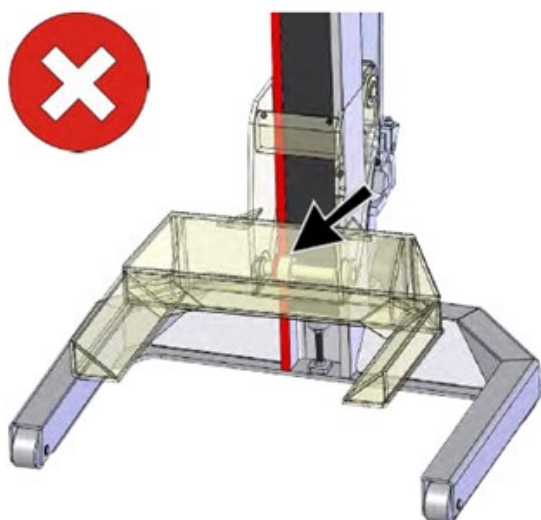
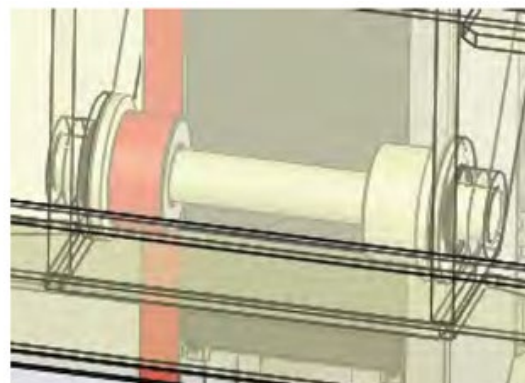
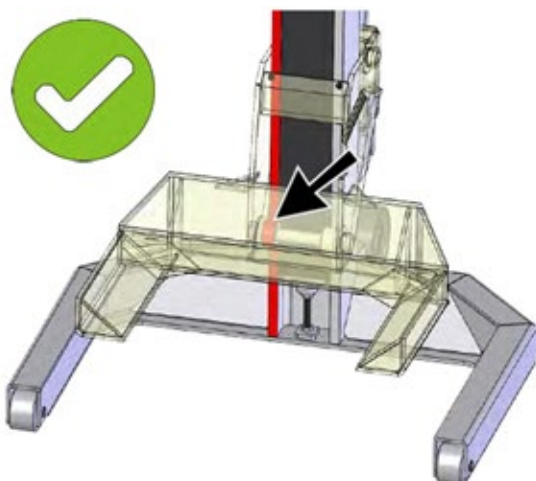

If it is possible to establish contact between the flange and the running surface on the column, the wear limit of the flange rollers has been reached. This means that the flange rollers including axle and thrust washers must be replaced.

If the nominal dimension is not reached, the safety wedge must be checked and adjusted. The new nominal dimension must be documented and used as the reference nominal dimension for the next test.

9.2.5 Spindle Lubrication, Spindle Lubrication Level

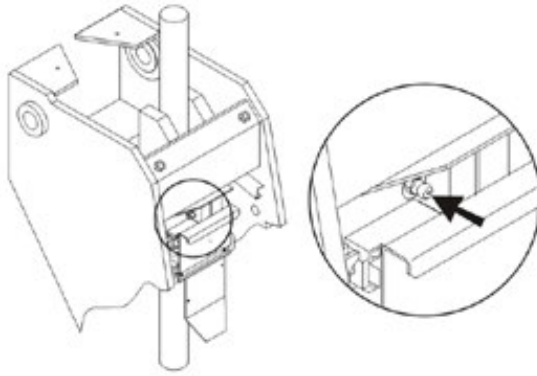

Lubricate the recirculating ball nut every six months using a grease gun. The grease nipple is located directly on the recirculating ball nut inside the lifting carriage.

Remove any dirt adhering to the spindle, paying particular attention to the spindle ends. A thin film of grease should be permanently present on the spindle.

9.2.6 Intermediate Safety Wedge Inspection

The safety wedge is used to secure the lift against uncontrolled lowering or falling, e.g. if the ball screw fails.

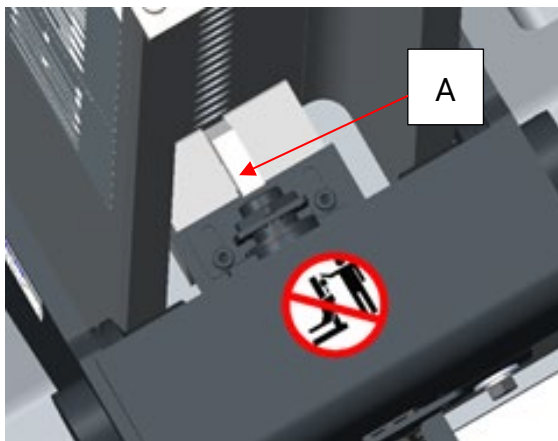

Inspection Part 1

The first thing to check is that the latch (A) can move freely, i.e. push the latch towards the column and release. The latch must return to its original position automatically and immediately after being released. In addition, a visual check for dirt, corrosion and damage to the galvanised wedges and the latch must be carried out.

Inspection Part 2

The lift must be moved to approx. half the lifting height for testing. Push the wedge (B) upwards so that it jams at the top. Press the lowering button until the wheel clamp stops (approx. 5-10 cm). The UP button then flashes and the DOWN button is not illuminated. Press the UP button and move up approx. 20 cm. The wedge should return to its original position (click sound). Then lower the lift completely. A system with a non-moving wedge and/or a damaged wedge must not be put into operation.

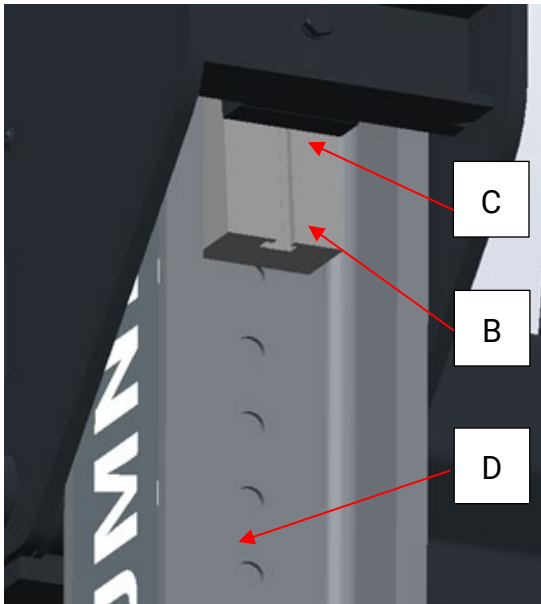

IMPORTANT:
The galvanised wedges (B, C) and the running surface (D) of the wedge must be kept free of lubricants and dirt.

9.2.7 Motor Retaining Ring

The retaining ring on the motor must be checked regularly to ensure safe operation of the system. This can be seen from above on the gear motor, see illustrations.

A visual inspection is required to check the retaining ring on the motor. Ensure that the retaining ring engages correctly in the groove.

A system without a retaining ring must be taken out of service!

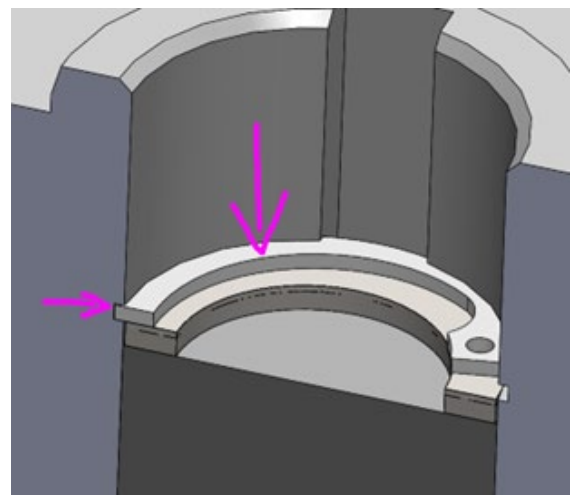
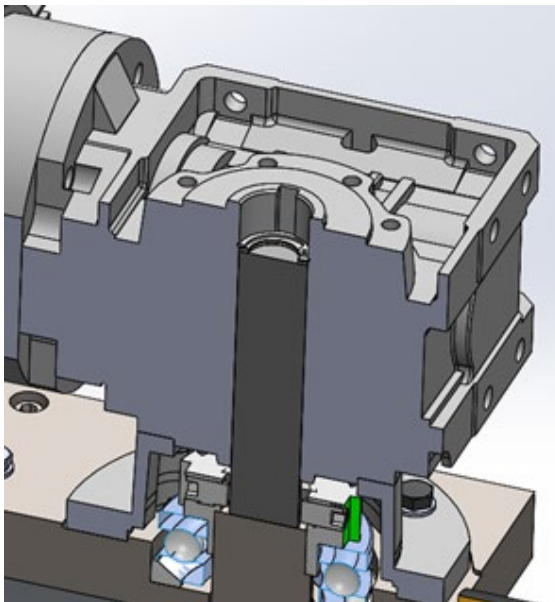

9.3 Yearly Inspection

There are country-specific requirements for the regular inspection of lifting equipment. These generally require an inspection of the safe operating condition after 12 months at the latest.

Irrespective of these regulations, the following inspection points must be checked at least every 12 months and corrected if necessary.

9.3.1 Chassis Rollers

Oil the rollers of the chassis at regular intervals or, if grease nipples are present, lubricate them with a grease gun.

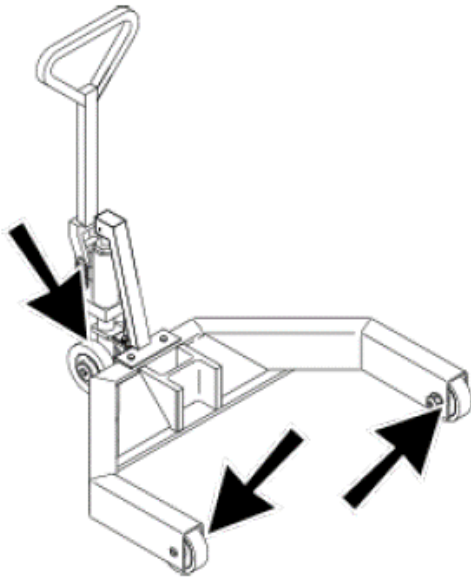

9.3.2 Screw Connections

Check the fastening screws of the load support for a tightening torque of 270 Nm and retighten if necessary.

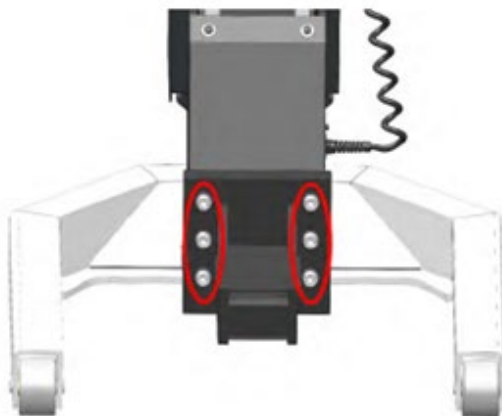

All other screw connections must be checked in accordance with EN 1493:2023-04 - B.1.3.

Thread	Strength class	Tightening torque [Nm]
M6	8.8	12
	10.9	16
M8	8.8	27
	10.9	38
M10	8.8	54
	10.9	76
M12	8.8	78
	10.9	110

9.3.3 Safety Wedge

At regular intervals, but at least once a year, the setting of the safety wedge must be checked by an expert and corrected if necessary.

After relevant repair and maintenance work (e.g. replacing the guide rollers on the lifting carriage), the inspection **must** be carried out. This also applies if there are visible deformations of the running surfaces on the lifting column and/or signs of wear on the rollers.

All tests and corrections must be documented.



WARNING

As dangerous conditions can arise during the test due to changes in the load distribution (load per wheel), this may only be carried out by trained service technicians. Proceed with extreme caution during the test!

Procedure

- 1 Lifting column loaded with a load in the range of 2/3 to 3/4 of the nominal load (i.e. approx. 5000....5600 kg for a nominal load of 7500 kg).
- 2 Raise the load to approx. 2/3 of full travel (i.e. approx. 1170 mm).



WARNING

Risk of injury! Never try to block the wedge by hand.

- 3 Clamp the safety catch manually by holding the moving part with a suitable object. A non-metallic rod or stick can be used to hold on to. Ensure that there is sufficient distance between the hand and all moving parts of the lifting column!
- 4 Move the lifting carriage downwards.



- 5 As soon as the wedge engages in the lifting column and the lifting carriage no longer moves downwards, release the operating button immediately.

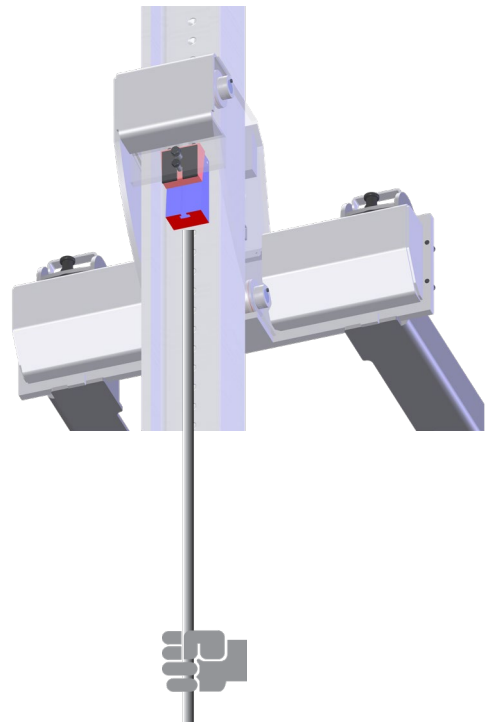

- 6 The uncovered section of the wedge back must now have a dimension of **31...40 mm**.
 - a. Dimension > 40 mm: Remove shim(s).
 - b. Dimension < 31 mm: Add shim(s)*.

* Parts kit mat. no.
1406147

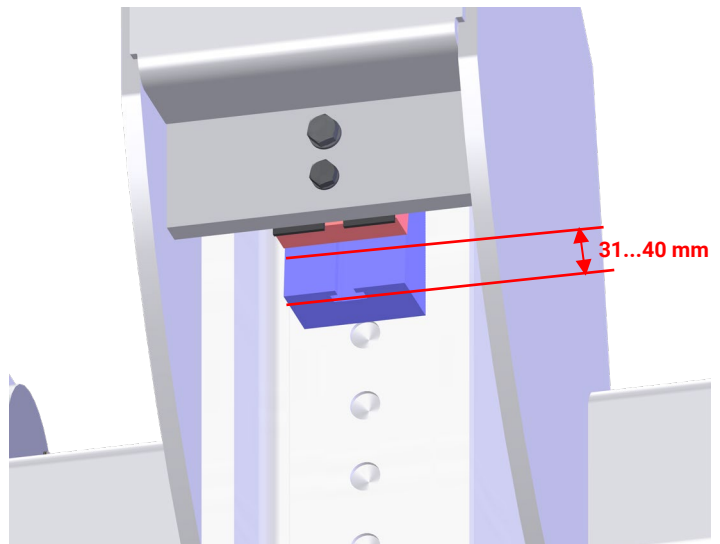

WARNING

Screws may **only** be loosened and shims removed or added when the lifting column is **not under load** !

A change of 0.5 mm in the thickness of the shim corresponds to approx. 5 mm of the free section on the wedge back. Make sure that **a maximum of 2.5 mm** of additional underlay is used. If more shims are required, the guide rollers and, if necessary, the axles on the lifting carriage must be replaced.

All changes to the number and thickness of the shims must be documented.

- 7 After this work, carefully tighten the fastening screws again. Tightening torque for **M12** thread: **65 Nm**
for **M10** thread: **40 Nm**
- 8 Then repeat the safety wedge test.

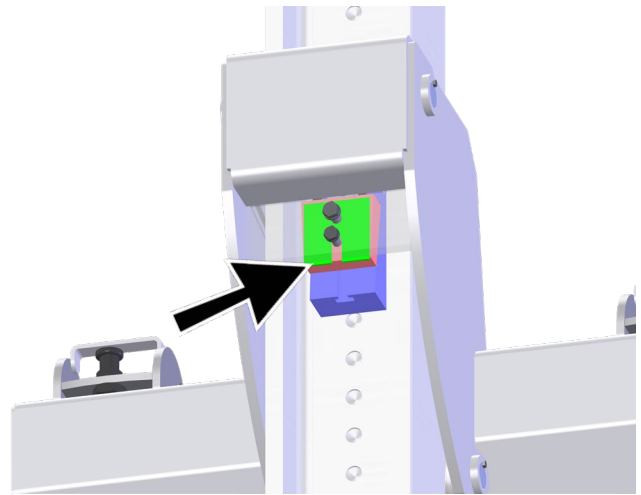

9.3.4 Obstacle Run



WARNING

Never perform the test under load!

If the lifting carriage or a wheel fork is blocked during downward travel, the lifting carriage stops and the spindle nut continues its lowering movement. The sensor, which is connected to the spindle nut, is activated and the system detects an obstacle and stops the lowering movement. To remove the obstacle, you can continue to move upwards.

To test, place a stable, largely non-slip obstacle (square timber, pallet, etc.) under the wheel forks.

Move the lift downwards. When the obstacle is reached, the spindle nut with the sensors must start to move upwards. After approx. 20 mm of spindle movement, the system must stop and the DOWN button goes out. Raising the lift must be possible.

9.3.5 Motor brake

The motor brake prevents uncontrolled movements of the lifting carriage, among other things, and must therefore be checked at regular intervals.

The minimum permissible braking torque is 28 Nm.

To check the permissible braking torque, this must be measured directly on the motor. This requires a long hexagonal screwdriver bit A/F 6, see illustration.

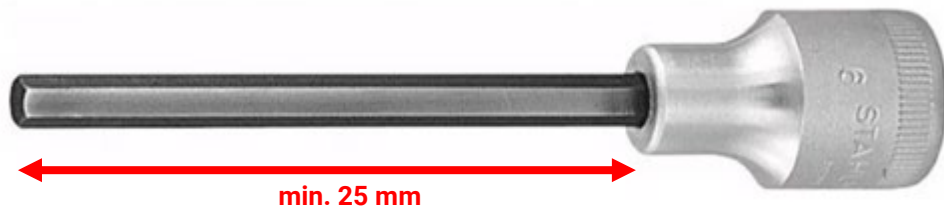

The fan wheel with cover is located at the rear of the motor (see illustration). In its centre is an opening for the screwdriver insert described above.

It is recommended to determine the braking torque using a torque wrench with a drag indicator.

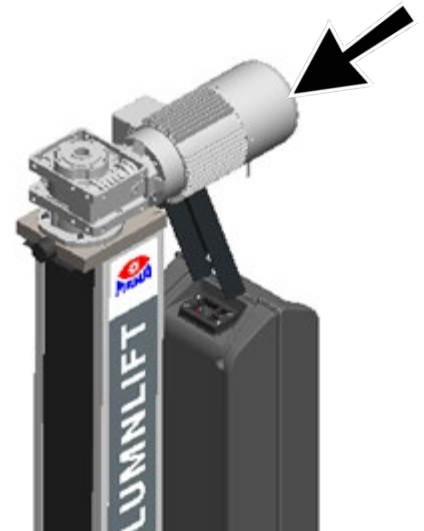

9.3.6 Carriage

For the subsequent tests, the lift must be moved to approx. 1/3 of its lifting height and the front cover of the lifting carriage removed.



- Checking sensors and switch plate
The sensor retaining plate is located inside the lifting carriage. All sensors must be checked to ensure that they are firmly seated. A switch plate is mounted on the lifting carriage, which must also be checked to ensure that it is firmly seated. Loose connections must be secured as described in the "Repair" chapter.

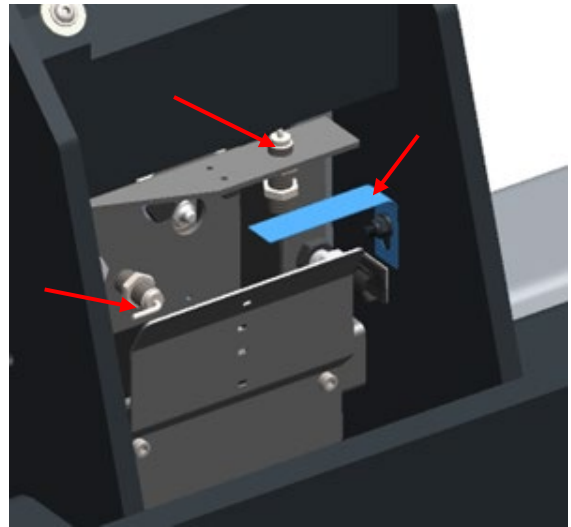

- Checking the end position

Move the lift all the way down until the lower end position is reached and the lift stops moving automatically. The wheel forks should not touch the ground. A minimum distance of 10 +5/-0 mm is set at the factory below the wheel fork. This distance is required for moving or positioning by means of the hydraulic dolly.

If the lifting carriage is on the ground or only stops moving after reaching the ground, the lower end position must be reset.

10 Servicing

Regular servicing ensures the function and operational safety of the lift and contributes to its value retention.

To ensure the safe operation and function of the lift, servicing must be carried out at the latest after the intervals specified in the servicing schedule.

Servicing may only be carried out by specially trained and authorized personnel. Such specialist staff include authorised, trained specialists employed by the manufacturer, the authorised dealers and the relevant service partners.

10.1 Safety Instructions



WARNING

- The relevant health and safety regulations must be observed.
- Wear personal protective equipment.
- Service work may only be carried out by authorised service technicians.
- Repairs, maintenance and set-up work should only be carried out when the machinery is stationary. The unit must be disconnected from the power supply and secured against being switched on again.
- Work on the electrical part of the lift may only be carried out by qualified staff or specialist electricians.
- Maintenance and repair work may only be carried out when the lift is load-free.
- Only use original replacement parts.
- Substances that are hazardous to the environment must be disposed of appropriately.
- Do not use high or steam pressure equipment or harsh cleaning agents to clean the lift.
- The safety devices of the lift must be adjusted by authorised service technicians.
- The safety features must not be replaced or overridden.

10.2 Lubrication

NOTICE

Only the following lubricants are permitted for servicing and maintaining the lift!

Lubrication points	Lubricants
Spindle / recirculating ball nut	Multi-purpose grease DIN 51502 K2K-30 IMPORTANT: Safe and trouble-free operation cannot be guaranteed if other lubricants are used!
Base frame axles	Multi-purpose oil / universal oil
Optional: Lifting carriage axles and external grease nipple for recirculating ball nut	Multi-purpose grease DIN 51502 K2K-30

10.2.1 Lubricating Spindle and Recirculating Ball Nut

NOTICE

If there is dirt in the oil pan, this can impair the running characteristics of the lift!

Lubricate the recirculating ball nut every six months with 4 to 7 strokes of a grease gun. By moving the lift several times (2 to 3 times) between the upper and lower end positions, the grease is distributed over the entire spindle. A thin film of grease should be permanently present on the spindle. Remove excess grease.

The grease nipple is located directly on the recirculating ball nut inside the lifting carriage.

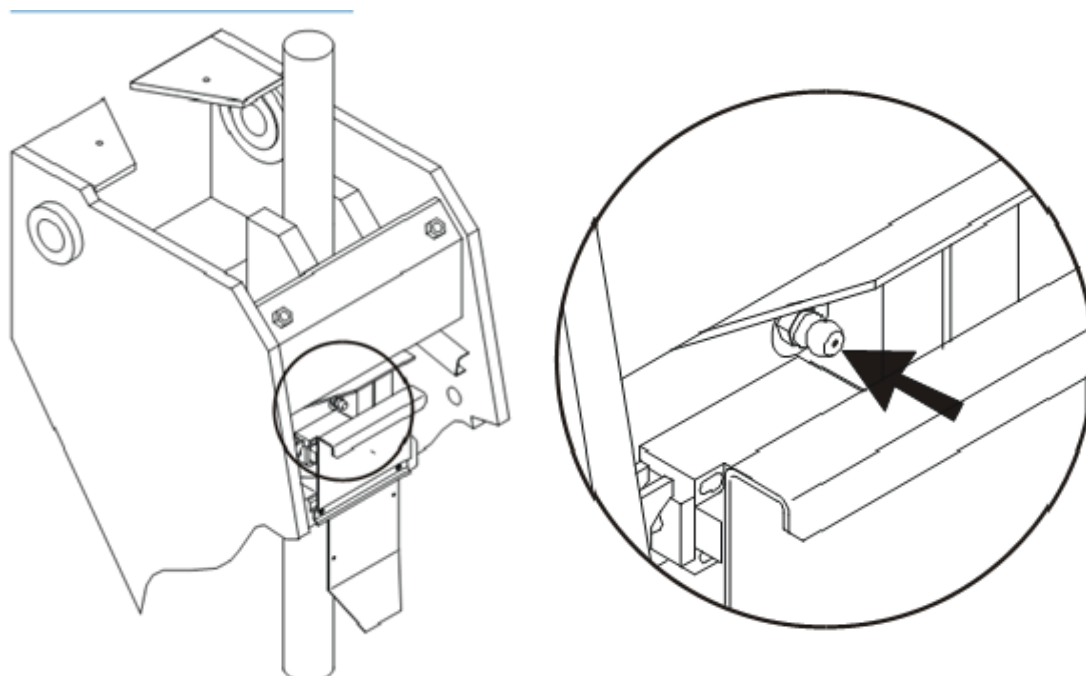

To access the grease nipple of the recirculating ball nut, the cover plate (4) of the lifting carriage and the upper fastening of the cover strip (2) must be removed. To do this, the screws (1) and (3) must be unscrewed. Once the cover strip has been folded down, the grease nipple in the lifting carriage becomes visible.

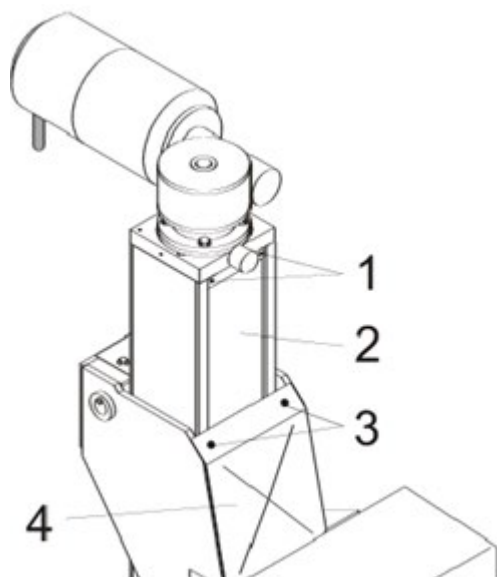

Screws (1) and (3)
Cover strip (2)
Cover plate (4)

10.2.2 Lubricating the Tracks of the Flange Rollers

Clean the tracks at regular intervals and coat them with a thin film of oil/grease. To do this, move the lifting carriage to different positions.

10.2.3 Base Frame

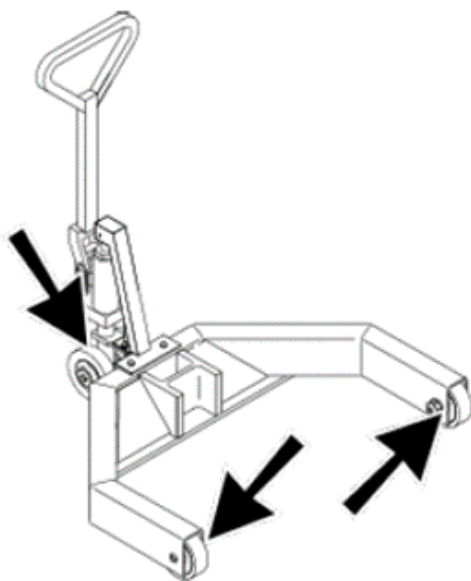

Oil the rollers of the chassis at regular intervals or, if grease nipples are present, lubricate them with a grease gun. Apply oil to rotating bearing points and distribute over the axles by moving the column.

10.2.4 Options

Grease recirculating ball nuts with external grease nipple every six months with 4 to 7 strokes of a grease gun.

Grease the greasable lifting carriage axles (optional) at regular intervals using a grease gun.

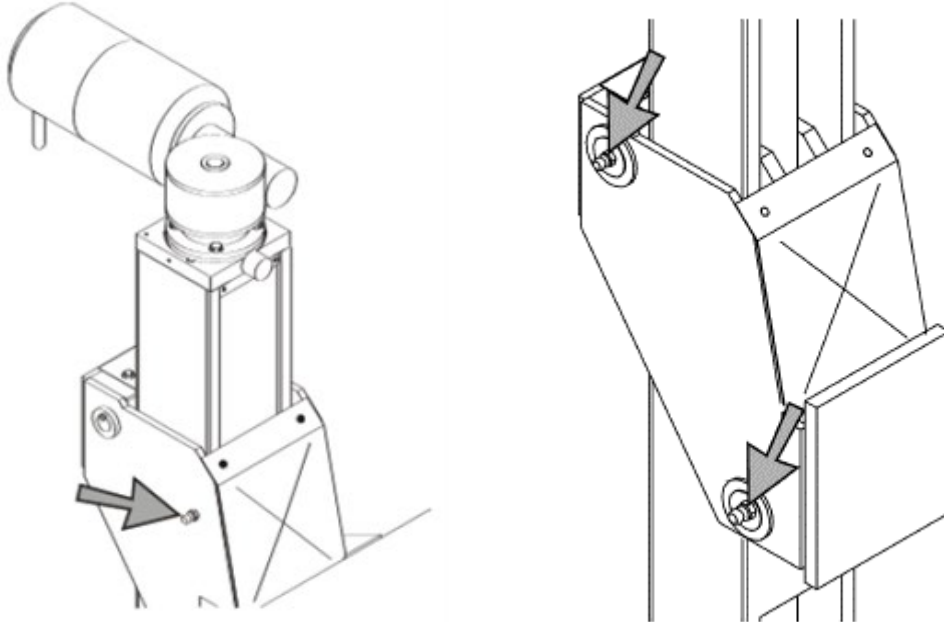

10.3 Replacing Flange Rollers and Axles

NOTICE

Only the complete replacement of this unit, consisting of one axle, two flange rollers and two thrust washers (see parts breakdown) is permitted.

Always replace damaged flange rollers promptly to prevent consequential damage to the lift. Procedure:

- 1 Move the lifting carriage to approx. 3/4 of the lifting height.
- 2 Hold the safety wedge with a suitable object (stick) and move the lifting carriage into the wedge.
- 3 Switch off the lift and activate the emergency stop.
- 4 Remove the cover plate on the front of the lifting carriage.
- 5 Remove the screw connection of the spindle cover at the top and bottom.
- 6 Undo the sensor and magnet plugs in the lifting carriage and guide them out of the lifting carriage to the rear together with the dismantled connecting plate of the energy chain.
- 7 Disconnect the motor cable from the motor (voltage and current-free!) and unplug the motor sensor cable.
- 8 Remove the screw connection between the hydraulic dolly and the column (4x M8).
- 9 Call in another person to hold the control unit for support.

- 10 Loosen the screw connection between the upper cable duct and the motor plate by approx. 5 mm and remove the entire operating unit including cable ducts (top and bottom) and hydraulic dolly from the motor plate and place on a suitable surface (cardboard).
- 11 Dismantle the motor incl. drive pin and motor plate.
- 12 Lift the lifting carriage upwards from the column using suitable lifting gear and place it on a suitable surface (lifting table). It is advisable to place the lifting carriage on the front panel.
- 12 Remove the dowel pins and remove the axles, flange rollers and thrust washers.
- 12 Assembly is carried out in reverse order.

10.4 Every 5 years

- Replace the silicone pads of the operating buttons.
- Replace the transmission oil.

11 Repairs



WARNING

Service and repair work on the lift may only be carried out by authorised and trained specialist personnel!

The lifting system and its components were extensively tested during development and before marketing. Original spare parts correspond in quality and condition to those of a new lifting system. To ensure the operational safety and longevity of your system, we recommend the exclusive use of original spare parts.

After repairing or replacing load-bearing parts, we recommend carrying out a functional test with a load to check the correct assembly, the movement of all parts and any settling behaviour.

For these tests, we recommend using a typical vehicle to be lifted with an empty weight of approx. 75% of the nominal load.

The nominal load specified on the rating plate must never be exceeded!

Overload tests to check the strength of the load-bearing parts were carried out as part of the conformity assessment procedure. The load-bearing capacity of the system and the relevant components was verified up to 1.5 times the nominal load.

Exceeding the rated load can lead to pre-damage to components and thus to increased wear and premature failure.

11.1 Manual Lowering



WARNING

Only for trained personnel! The lift must not be put back into operation until the fault has been eliminated.

Before manual lowering can begin, it is essential to check the safety wedge on each column. The test consists of a visual and functional test. See section "Intermediate Safety Wedge Test".

If the safety wedge is active or collapsed and it is not possible to move up, the affected column must be replaced. The entire group must be secured using support stands!

Procedure:

- For manual lowering, the unlocking rod must be screwed into each lifting column. This can be found in the document folder for the respective column.

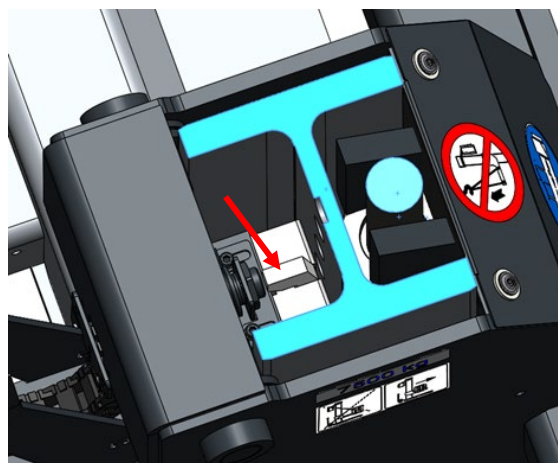
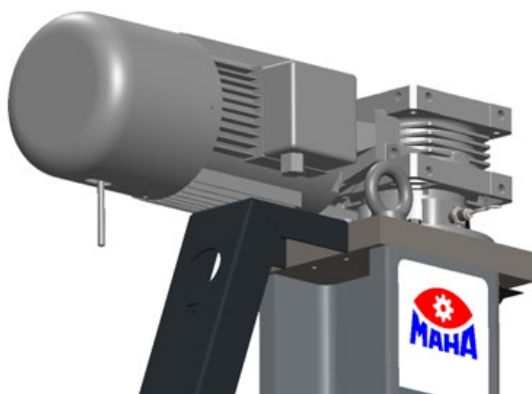

- Override the safety wedge. This can be achieved by clamping an approx. 10 mm wide slotted screwdriver. The safety wedge may only be deactivated temporarily on the column that will be lowered next.
- Lower the column max. 50 mm by pushing the unlocking rod. Restore the function of the safety wedge by removing the screwdriver.
- Repeat the lowering by 50 mm on each of the other columns of the group so that it is again parallel to the initial situation or to the floor. Repeat the process in max. 50 mm steps until the group is on the floor.
- Alternatively, support the vehicle securely on support stands and replace defective lifting columns.

IMPORTANT:

If the raised vehicle is too light, activating the brake release may not be sufficient. To lower the vehicle, use a hexagon socket wrench to turn the motor while the brake is actuated (see section "Motor brake").

11.2 Operating Unit

Service position Operating unit:

The front half (A) of the operating unit can be mounted in a service position, in which case another person is required for support. Unscrew the 4 flat head screws on the front using a hexagon socket A/F 3 and refit the front half rotated by 90°. The service position is required for all further work on the operating unit. The tightening torque of the screw connection is 3.5 Nm.

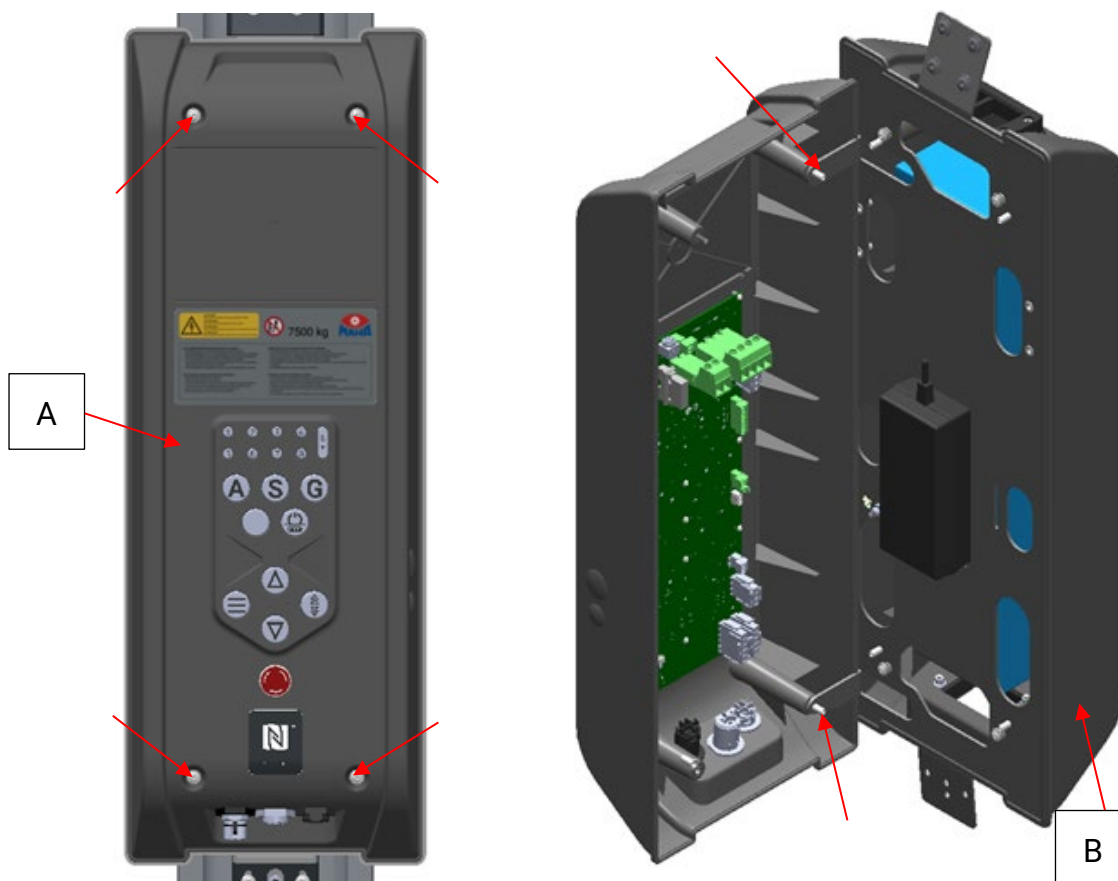

11.2.1 Replacing Charger and Battery

The charger is fastened together with the battery to the support plate between them using a tensioning strap.

Replacing the charger

The charger is plugged into the circuit board. Loosen plug connections. Loosen the tensioning strap and replace the charger, retighten the tensioning strap and restore the plug connections.

Replacing the Li-ion battery

The plug connection to the circuit board must be disconnected, then the rear operating housing (B) must be removed. To do this, remove 4 flat head screws with A/F 3 hexagon socket. Push the rear operating housing to the side until the battery can be replaced. Use a tensioning strap to check that the battery and charger are securely fastened. Re-establish the plug connection to the circuit board.

11.2.2 Replacing Circuit Board, Emergency Stop Switch and Silicone Buttons

To replace the circuit board or the silicone buttons, disconnect all plug connections on the circuit board, starting with the battery connection. For all further disassembly steps, we recommend removing the front operating housing and placing it on a flat surface (use a base to avoid scratches). Loosen the screw connection between the circuit board and the plastic housing (tool size TORX T10). If necessary, replace the circuit board, emergency stop switch or silicone buttons and install in reverse order. Note the tightening torque of the circuit board screw connection: max. 0.7 Nm.

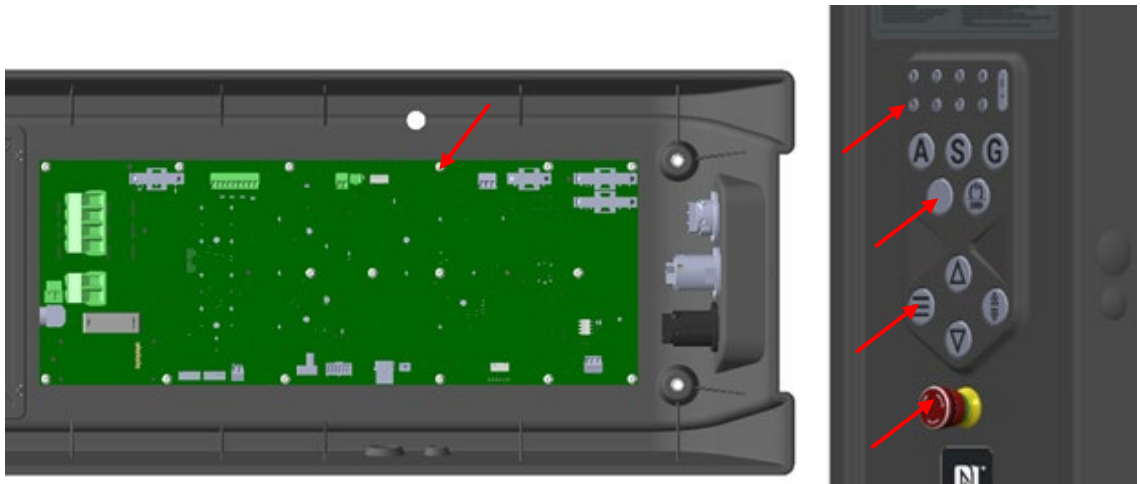

11.2.3 Replacing the Sockets for Cable Connection

The sockets including connection cable to the circuit board are located in the lower area of the front operating housing. These can be removed and replaced by unplugging them from the circuit board and loosening the plastic nut inwards.

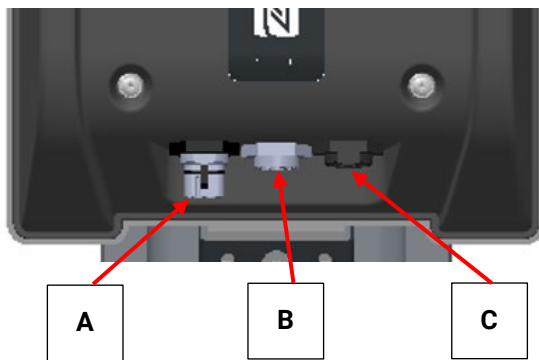

- A Input of cable connection
- B Connection 8+8
- C Output of cable connection

11.3 Replacing Sensors

The position of the sensors on the sensor retaining plates is preset ex works. If a defective sensor is replaced, the sensors must be installed as follows.
IMPORTANT: The correct sensor position has to be marked with a threadlocker.

11.3.1 Replacing the Speed Sensor

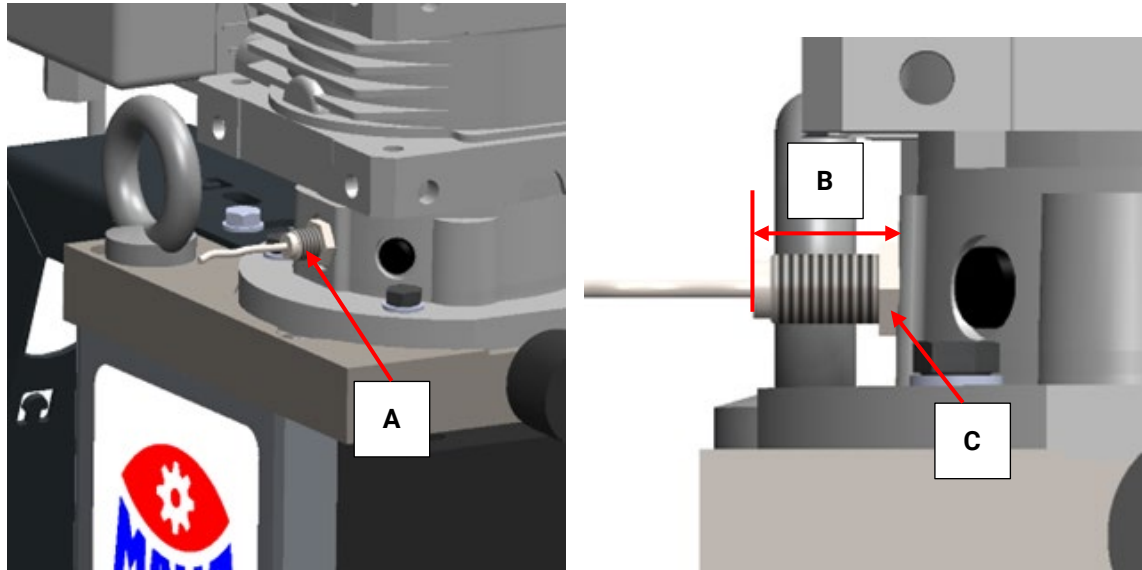

To replace the speed sensor (A), set the operating unit to the service position as described in section “Operating Housing”. Before replacing the sensor, the screw-in depth (B) of the sensor must be determined as precisely as possible in order to screw in the replacement sensor exactly as far as the existing one. This is necessary for the function and safe operation of the lifting system. To screw the sensor in and out, loosen the lock nut (C) and unplug the connection to the circuit board. Screw in the replacement sensors to the determined depth and secure with a tightening torque of 25 Nm.

Adjustment of speed sensor using software (alternative):

If repairs are required, the speed sensor located on the motor gearbox must be adjusted and checked. To do this, the speed sensor is first screwed all the way into the motor gearbox (light contact) and then unscrewed again by 3.8 turns.

To check, the lifting carriage must be moved slightly (at least 10 cm). During each run, the control unit measures the ratio of the pulse duration to the period duration of the speed sensor. The duty cycle should be between 40 and 60% (read value must be between 400 and 600). The ideal value would be 50%, which corresponds to a read value of 500.

Measured value	Action on the sensor	Reference
Too big	Turn right	1/2 turn corresponds to 100
Too small	Turn left	1/4 turn corresponds to 50

If the speed sensor is readjusted, a new test drive must be carried out. The duty cycle of the speed sensor can then be read out and evaluated again.

11.3.2 Replacing Safety Sensor and Proximity Switch for Lower End Position

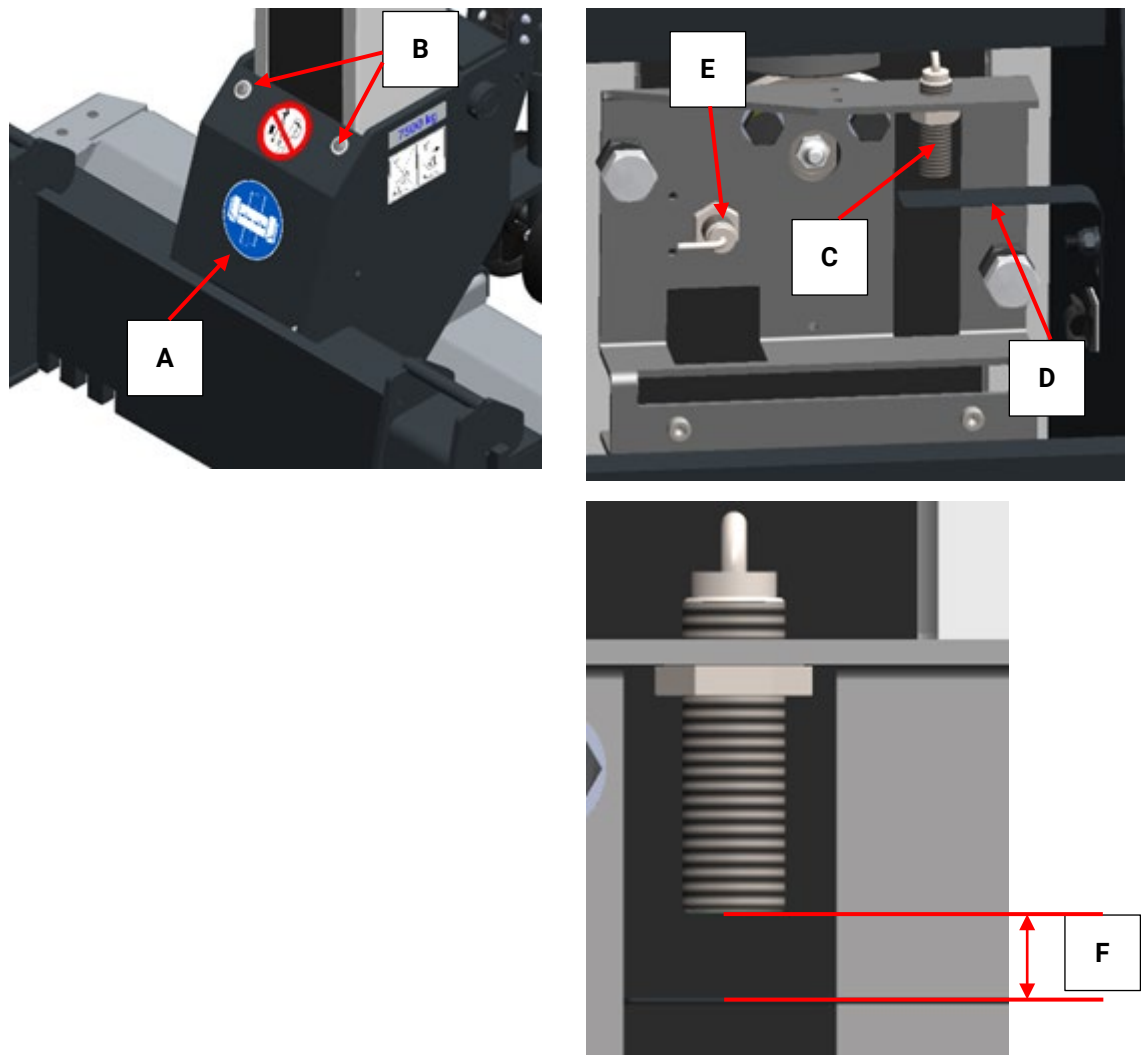

To replace the safety sensor and the proximity switch for the lower end position, the cover (A) must be removed by loosening the screw connections (B) (hexagon socket A/F 5).

Before replacing the sensor, the screw-in depth of the respective sensor must be determined as precisely as possible so that the replacement sensor can be screwed in exactly as far as the existing one. Then unplug the sensors and remove the cable ties for fastening. The lock nuts must be loosened to remove the sensors. Screw in the replacement sensors to the determined depth and secure with a tightening torque of 25 Nm.

The distance (F) between the safety sensor (C) and the mounting bracket (D) must also be checked. The distance (F) must be set at 10 ± 2 mm. The correct setting of the proximity switch for the lower end position (E) can only be made during operation.

During installation, particular attention must be paid to the correct connection of the sensors. This means that the sensor cable of the safety sensor marked "X14" must be connected to cable "X14" and the sensor cable of the proximity switch for the lower end position marked "X8" must be connected to cable "X8". Guide the cable around the spindle cover and secure the sensor cable using cable ties.

11.4 Drive Train

11.4.1 Replacing the Motor with Drive Pin

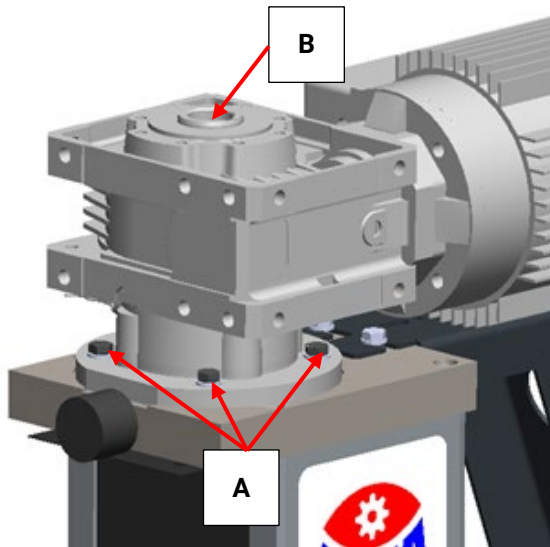

The speed sensor must be removed to replace the gear motor. To do this, the setting dimension must be documented as described in section “Replacing the Speed Sensor”.

To replace the gear motor, proceed as follows:

- Disconnect the motor cable (document the assignment on the terminal board).
- Remove circlip and washers (B).
- Secure geared motor with lifting gear (slip) between motor and gearbox.
- Loosen all four M8 hex head screws (A) on the head plate (A/F 13).
- Lift down the gear motor, paying attention to the loose drive pin, which can be removed in the direction of the drive axle.
- Mount the replacement motor on the head plate using the 4 hex head screws (tightening torque 25 Nm). Insert the drive pin and refit with washers and circlip.
- Connect the motor cable and set the speed sensor correctly.

11.4.2 Replacing the Spindle with Bearing

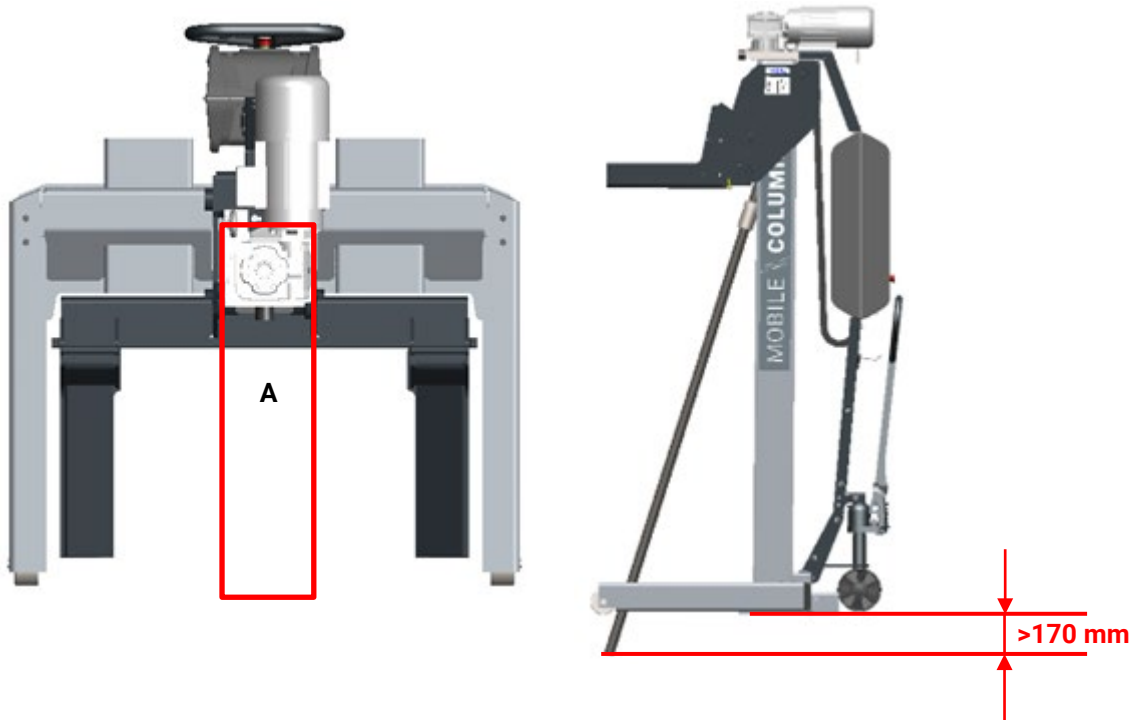

- To remove the spindle (B), the column must be in a raised position or there must be a free space in the marked area (A).
- Move the column to upper end position.
- Lower the lifting carriage into the safety wedge, i.e. hold the wedge and press the DOWN button until the lifting carriage settles on the wedge. Also secure the lifting carriage against falling. Switch off the lift.
- To replace the spindle, the motor must be removed. See previous section "Replacing the Motor with Drive Pin".
- Remove the nut (C) from the lower floating bearing and push the bearing cup (D) downwards. The lower end of the spindle should be freely movable.
- Document the screw-in depth of the threaded pins (E) for later installation. Attention: Threaded pins are and must be glued in again with medium strength.
- Then remove threaded pins A/F 6 (E).

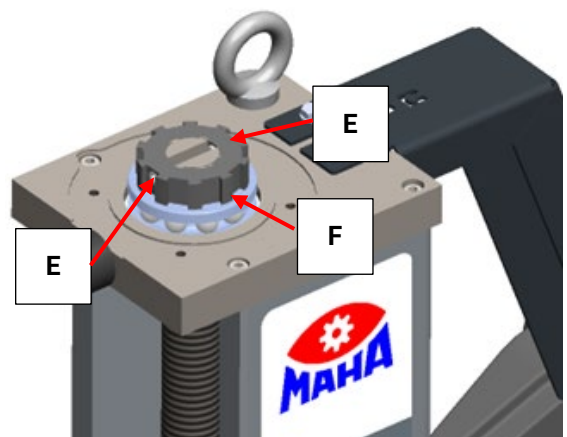
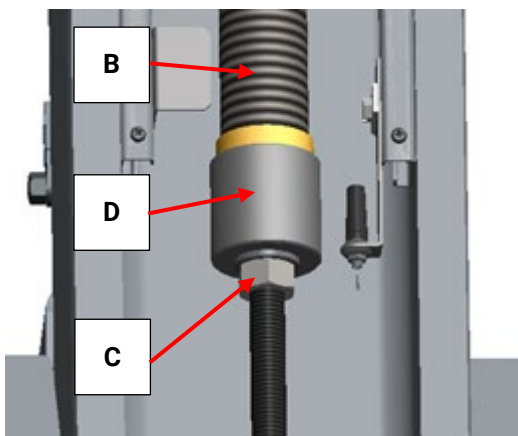

- The groove nut (F) is the connecting link between the hanging spindle and the head plate.
- When the groove nut is turned down, the spindle can be removed downwards. Make sure that the spindle is held in place or secured against falling out. Another person must be called in for this work step.
- Assembly is carried out in reverse order.
- Pay particular attention to the correct positioning of the locknut (F).
- Screw in the locknut until it is flush with the top of the spindle. If this is not possible, the locknut may be turned to the next possible position.

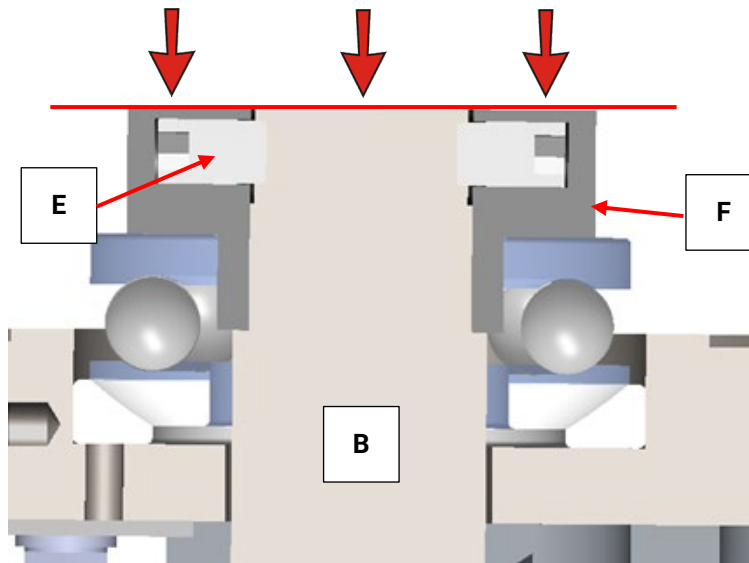

11.5 Replacing Solenoid and Safety Wedge

Replacing the Solenoid

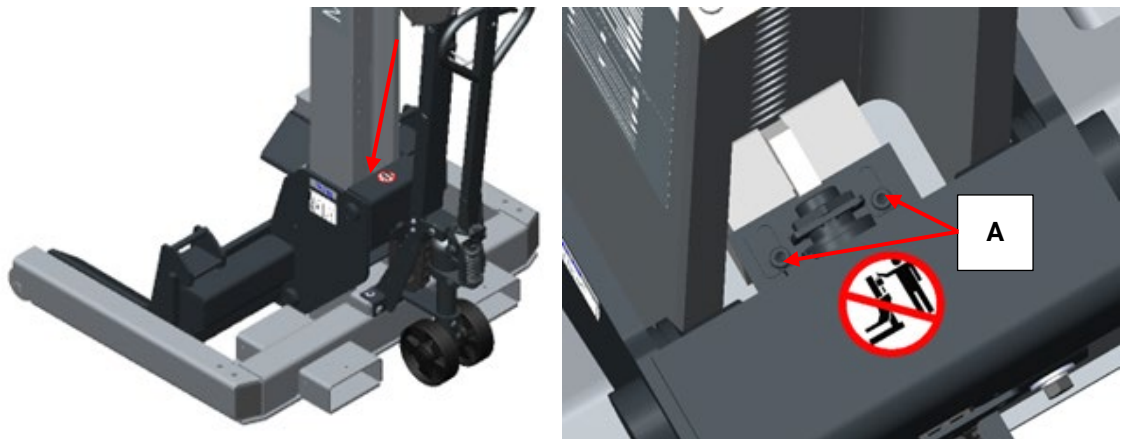

- To replace the solenoid, which is required to actuate the latch, remove the two M6 cylinder head screws with an A/F 5 hexagon socket.
- Then loosen the screw connection of the solenoid plug and remove it.
- Only the replacement of the assembly: solenoid incl. pre-assembled mounting plate is permitted.
- Observe the original mounting position of the assembly with regard to the slotted holes and mount in the same way.

- Assembly is carried out in reverse order.

Replacing the Safety Wedge

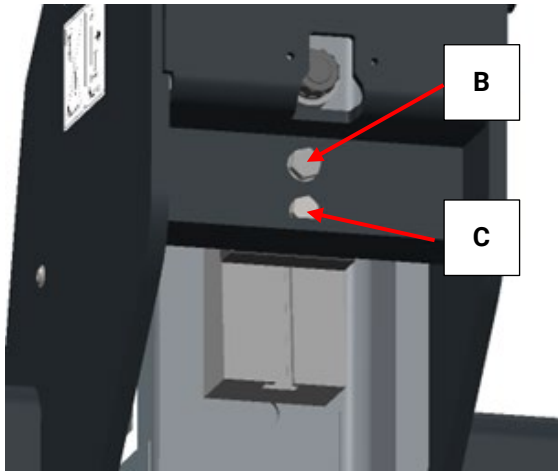

- Move the column to approx. 2/3 of its travel or until the lifting carriage is at a comfortable working height.
- Switch off the lift and securely support the lift carriage in a suitable manner.
- Remove the solenoid, see section “Replacing the Solenoid”.
- Remove the cable carrier from the lifting carriage (hex socket A/F 4) and temporarily fasten it to the side.
- Remove the hex head screw (C), loosening the spacer plates and the sliding block. (Attention: components fall out at the bottom!)
- Both wedge halves are now connected with the hex head screw (B). If this is dismantled, both parts come loose. (Attention: components fall out at the bottom!)
- Assembly is carried out in reverse order. Both halves of the wedge and the spacer plates must be replaced. We recommend using the same number or thickness of spacer plates again. The spacer plates are available in sheet thicknesses of 0.5 mm, 1 mm and 2 mm.
- Then check the function as described in section “Checking the Safety Wedge” and adjust the spacer plates if necessary.
- Tightening torque screw (B): 65 Nm, screw (C): 50 Nm

11.6 Adjusting the Hydraulic Dolly

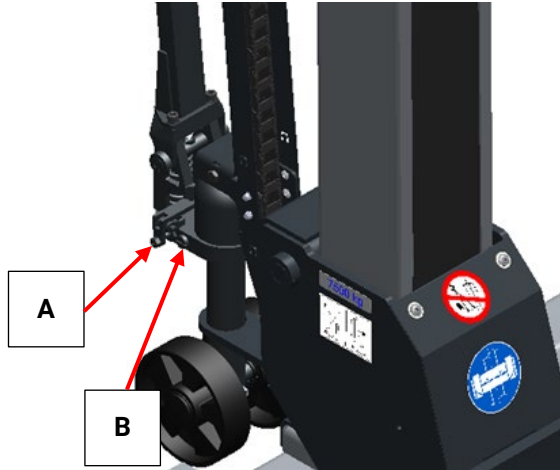



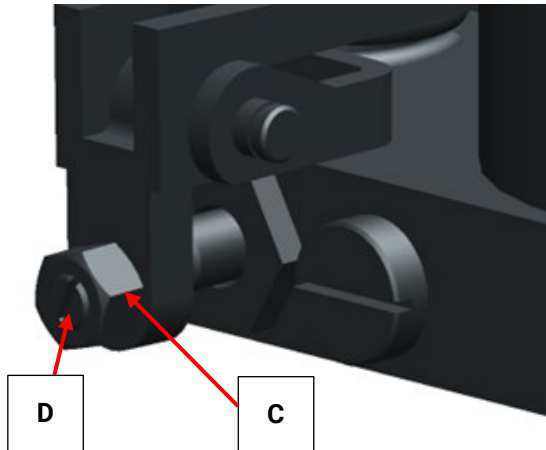

The lowering speed (A) and the response sensitivity (B) can be set on the hydraulic dolly.

11.6.1 Adjusting the Lowering Speed





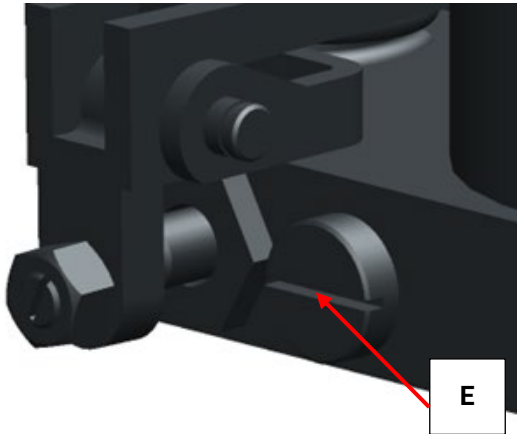

The lowering valve can be adjusted using the threaded pin with an Allen key, holding the lock nut with an open-end wrench. Carefully lower the dolly to check the setting.

Threaded pin	 Open	Increase 	Lowering speed
	 Close	Decrease 	

11.6.2 Adjusting the Automatic Lowering Function



The valve for the automatic lowering function is located next to the lowering valve. Remove the screw plug with a slotted screwdriver, then set the adjusting screw with an Allen key. Place a cloth underneath for escaping hydraulic oil. Tighten the screw plug again.

Adjusting screw	 Open	Decrease 	Response sensitivity
	 Close	Increase 	

11.6.3 Topping up the Hydraulic Oil on the Dolly

Hydraulic oil	Quantity
ISO VG32	approx. 0.3 L

- Dolly is fully lowered.
- Open the oil filler plug above the valves described above.
- Top up the oil to the mark. If there is no marking, top up the oil to the lower edge of the filler plug.
- Close the oil filler plug and ensure that the O-ring is correctly seated.

12 Decommissioning, Dismantling and Disposal

The device may only be taken out of operation and disassembled by specially authorised and trained personnel. Such specialist staff include authorised, trained specialists employed by the manufacturer, the authorised dealers and the relevant service partners.

Observe the product and safety data sheets of the lubricants used. Avoid environmental damage. If the device is to be disposed of, it must be disposed of in an environmentally responsible manner in accordance with local legislation. Sort all dismantled materials according to type and take them to a suitable recycling point. Collect operating materials such as grease, oil, coolants, cleaning fluids containing solvents, etc. in suitable containers and dispose of them in an environmentally friendly manner.

Alternatively, you can take your device to a waste management company. They will ensure that all parts and fluids are disposed of properly and ecologically.

12.1 Disposal of Batteries

As a distributor, MAHA is obliged to take back aged or defective lithium-ion batteries. However, to reduce costs and effort, it is advisable to return them to a local waste disposal company.

13 Control Board

13.1 Assignment of the DIP Switches

On delivery, all DIP switches are in the OFF position (default).

DIP switch S2

DIP setting				Description	
OFF					
ON					
	OFF			CE stop Yes	(software-dependent)
	ON			CE stop No	(software-dependent)
		OFF		Li-ion battery	(software-dependent)
		ON		AGM battery	(software-dependent)
			OFF		
			ON		

14 Configuration Program

Predefined settings can be adjusted as required using the configuration program. It is controlled using the buttons on the control panel.

14.1 Overview of Available Configurations

Config. no.	Description	Setting 1	Setting 2	Setting 3
1	Radio standby	1 = no radio standby. The radio channel remains occupied as long as the lifting column is switched on and the network is closed.	2 = Activate radio standby after 5 min. The occupied radio channel is released if there is no more lifting movement during this time.	-
2	Not assigned	-	-	-
3	Not assigned	-	-	-
4	Not assigned	-	-	-
5	Not assigned	-	-	-
6	Not assigned	-	-	-
7	Not assigned	-	-	-
8	Not assigned	-	-	-

14.2 Start Configuration Program

The lifting column must be switched off.

Press and hold the FUNC and SINGLE buttons together.

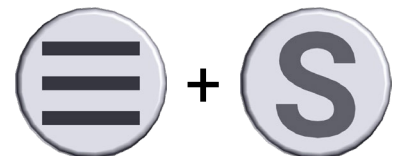

Press the ON/OFF button briefly to switch on while keeping the FUNC and SINGLE buttons pressed.



When the signal transmitter outputs a triple signal, release the FUNC and SINGLE buttons. The error lamp now lights up as long as the configuration program is active.

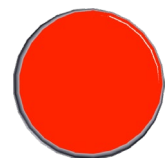

The lifting column lamp 1 starts to flash.

Continue with "Select Configuration Number".

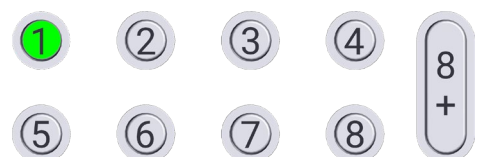

14.3 Select Configuration Number

The lifting column lamps 1...8 each flash to indicate which configuration number can currently be changed.

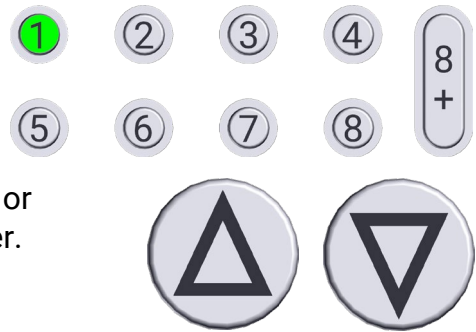

Use the UP or DOWN button to scroll forwards or backwards to the desired configuration number.

Continue with "Display, Change and Save Configuration Value".

14.4 Display, Change and Save Configuration Value

Press the FUNC button to display the current setting of the configuration value. Then one of the lifting column lamps starts to light up continuously.

In this example, setting 2 is active.

Use the UP or DOWN button to scroll to the desired setting.



To save the new setting, press the FUNC button for 2 seconds until a flashing lifting column light displays the configuration number again.

If you do not want to change the configuration value or want to discard a setting you have just made, simply press the FUNC button briefly. This returns to the output of the current configuration number without making any changes.

Continue with "Exit Configuration Program".

14.5 Exit Configuration Program

To exit the configuration program, briefly press the ON button. This closes the configuration program, and the lifting column switches off. If no button is pressed for 5 minutes, the configuration program exits automatically.

15 Annex

See following page(s).

15.1 Electric Circuit Diagrams

15.2 Product Datasheets

15.3 Declarations of Conformity

Electric Circuit Diagrams



MAHA
Maschinenbau Haldenwang GmbH & Co. KG
Hoyen 20
87490 Haldenwang
Germany

Equipment designation: RGA mobile column lift
Drawing number : 228.05.005868A

Option: 8+8 data connection

Dieser Schaltplan wurde für den maximalen Ausbau der Maschine erstellt. Optionsbedingt können Abweichungen zwischen Steuerung und Schaltplan vorhanden sein.
This circuit diagram is intended for machines equipped with all options. Options appearing in the circuit diagram need not necessarily be present in the control unit.

Serial Number

Power supply : 1x 110/230V, N, PE, 50/60Hz
Fuse protection : B 16A (RCD 30mA)

Created on : 30.03.2022 by: BFU
Last modified : 13.11.2023 by: BFU

▶ SN + Barcode ◀

Information to the electrical diagram

- Explanation of the reference marking (RKZ) according to DIN EN 81.346:

Symbol "=" meant: Type of the plant

Symbol "+" meant: Location of the construction unit

Symbol "-" meant: Designation of the construction unit

Example:

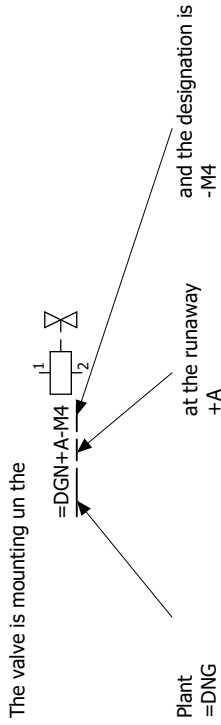

Since our plants and their controls can be assigned clearly, it is to be let be omitted permitted with the RKZ the plant designation. The RKZ will look as follows in our plants:

+A-M4

A construction unit on a electrical diagram page is drawn in, in whose header "+S", must the place name is registered "+S" before the designation of the construction unit are set.

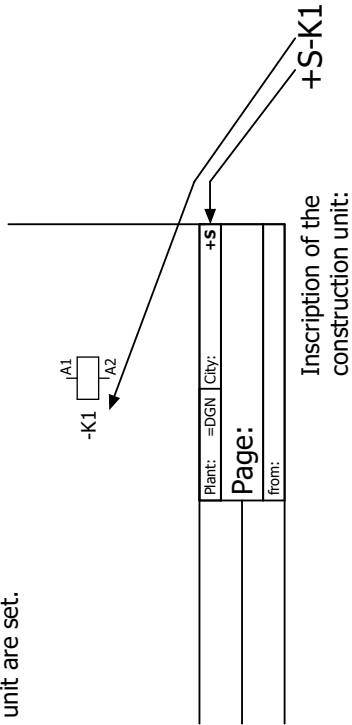

If a local box is drawn around a construction unit, then this has always priority, before the header

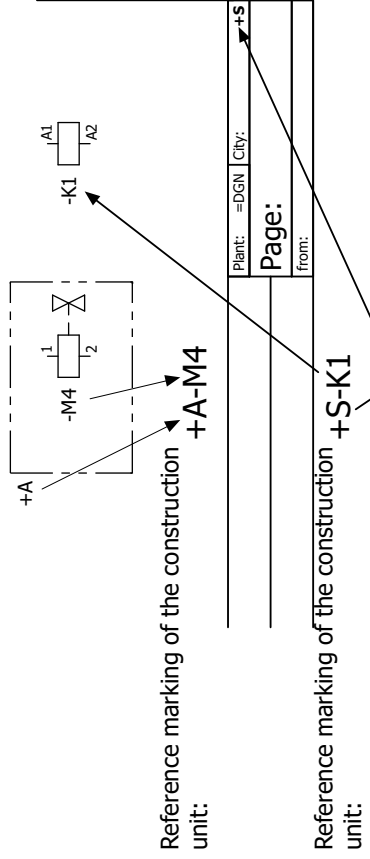

Another type of representation permits a doing without the local box. The describing place must be set before the construction unit designation:

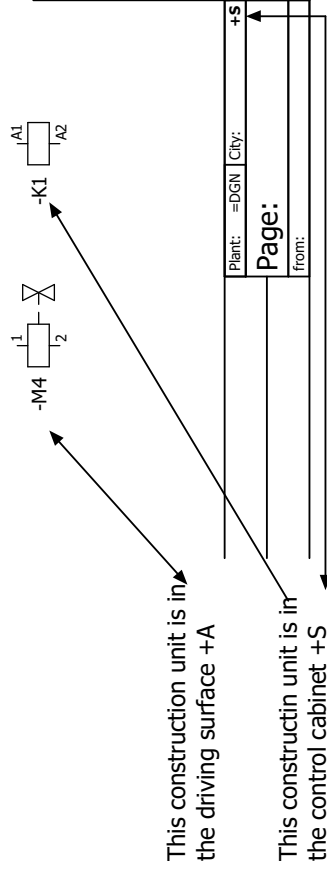

In this plant the following place names are relevant:

- " +S" - Switchgear cabinet
- " +A" - Driving surface / Post
- " +B" - Driving surface / Post
- " +C" - Hydraulic aggregate
- " +D" - outside of the equipment
- " +S1" - external control unit
- " +S2" - foot control unit

Option: AGM batteries

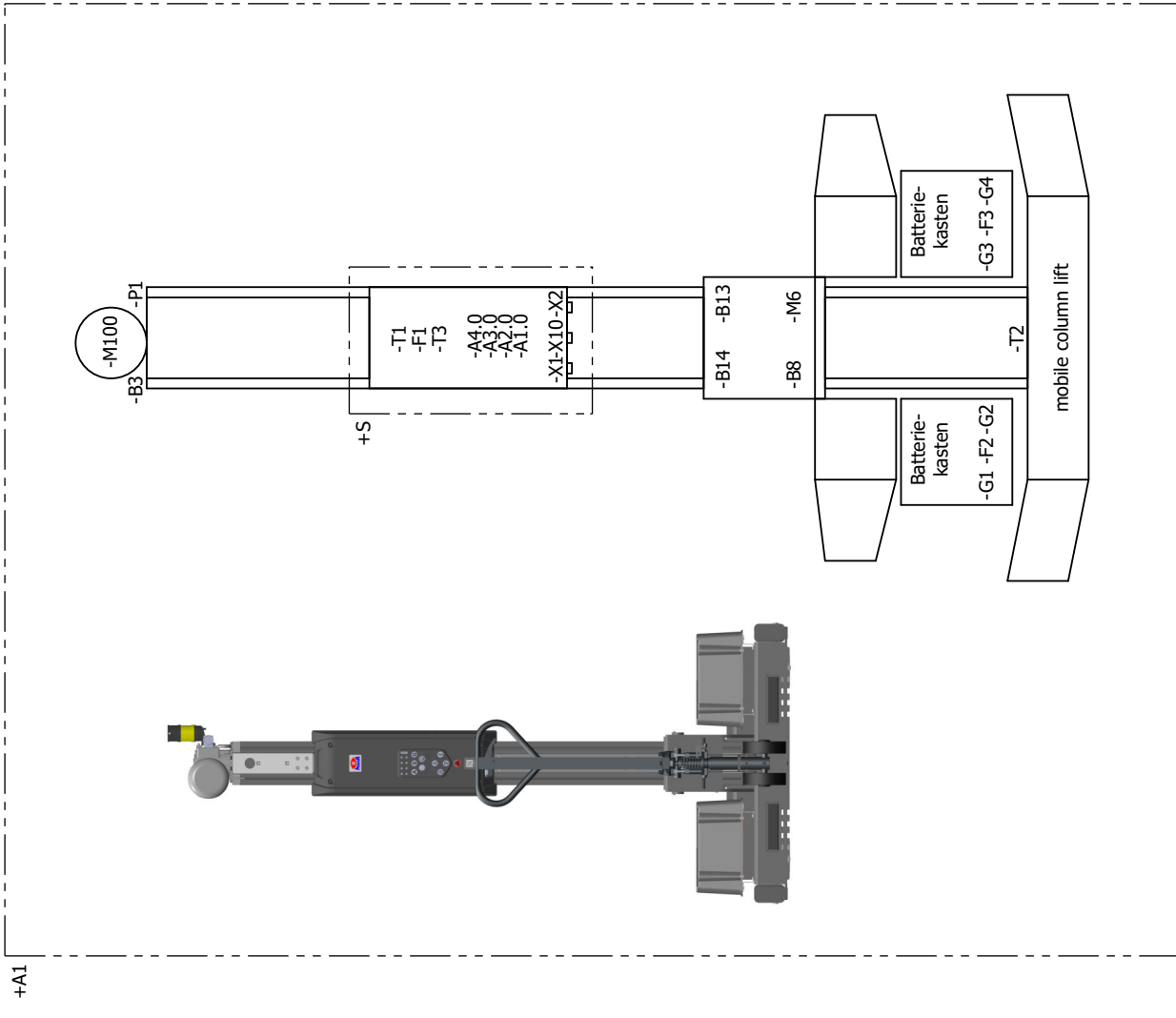
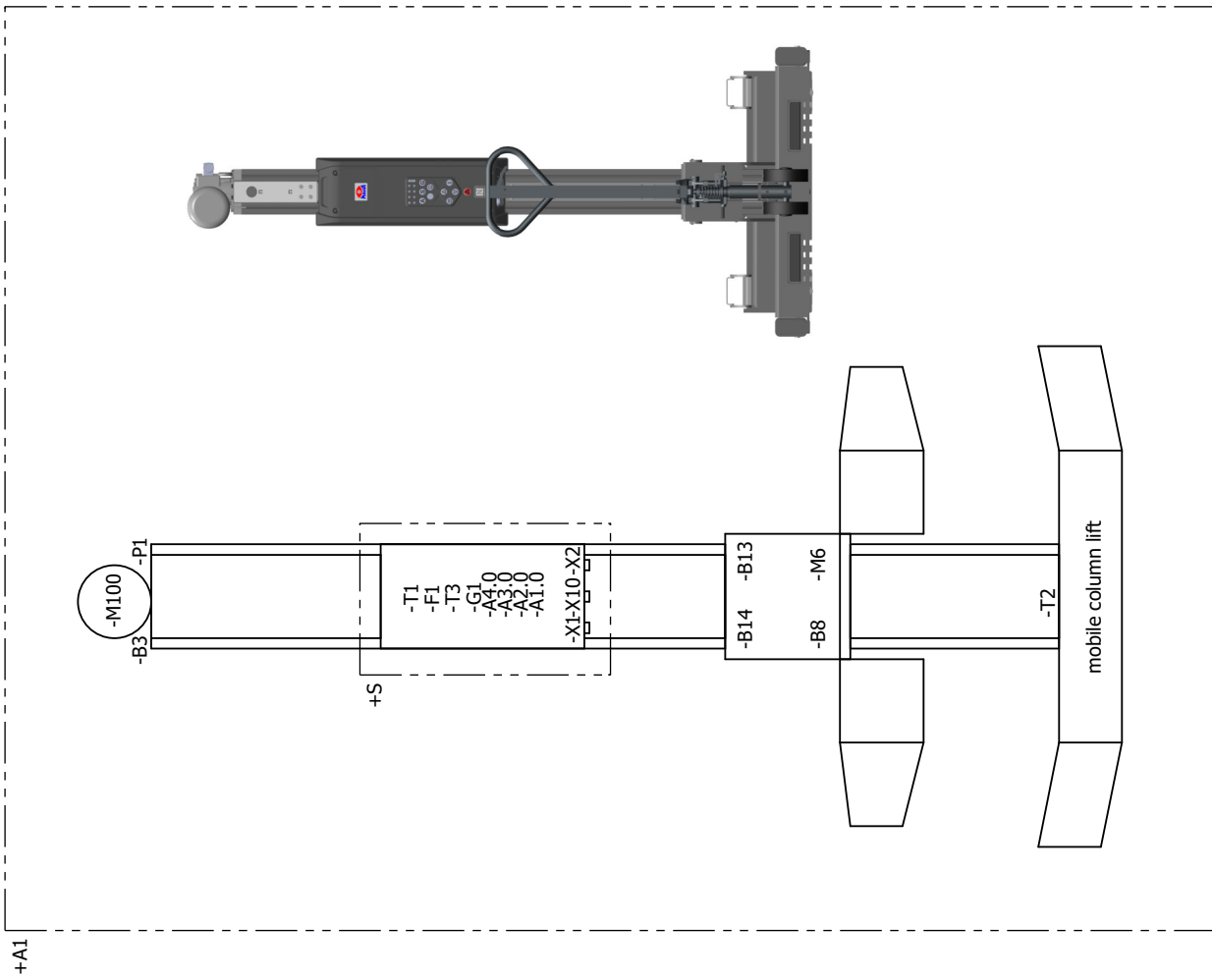

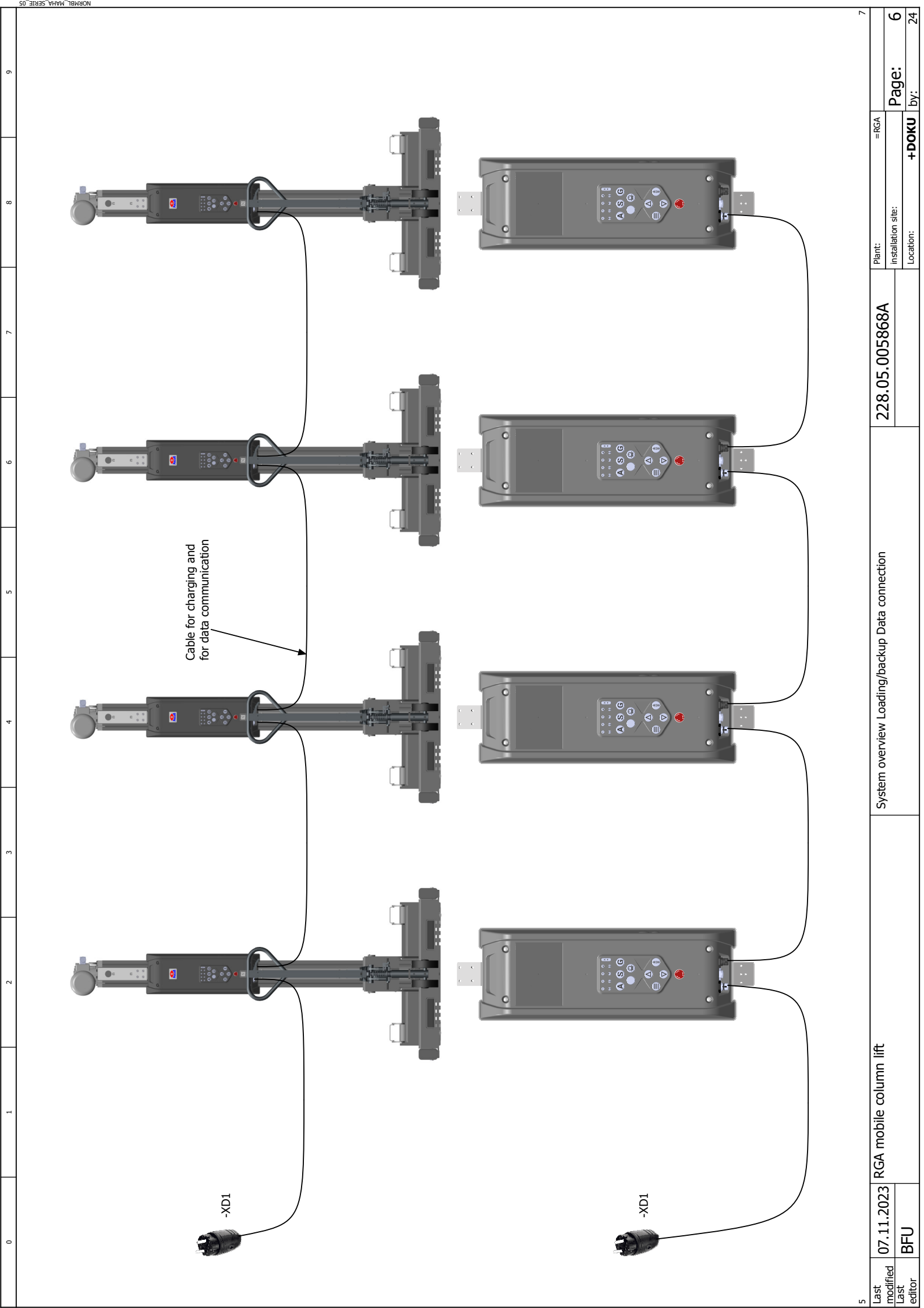

0

1

2

3

4

5

6

7

8

9

-XD1

-XD1

Cable for charging and for data communication

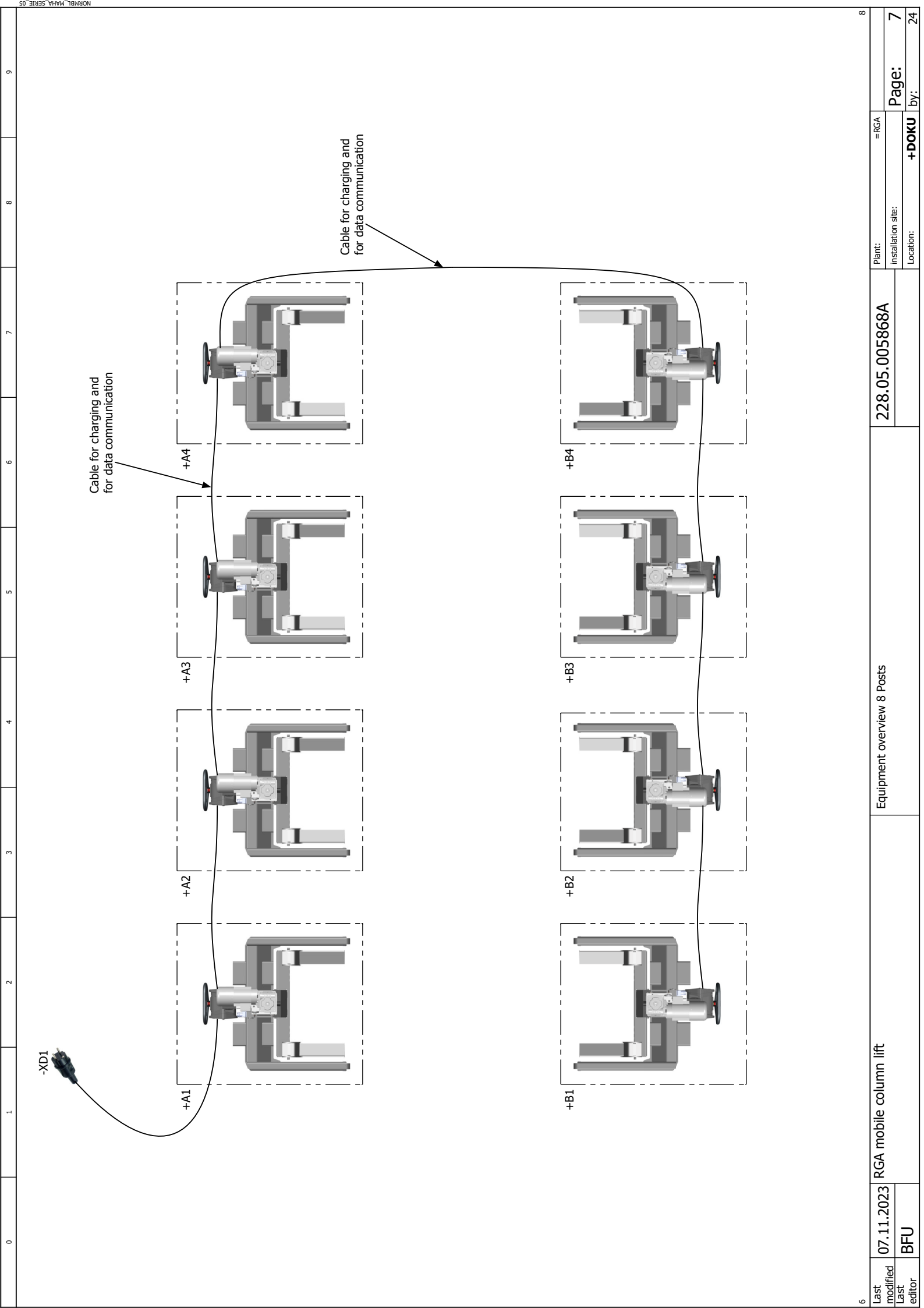

-XD1

Cable for charging and for data communication

Cable for charging and for data communication

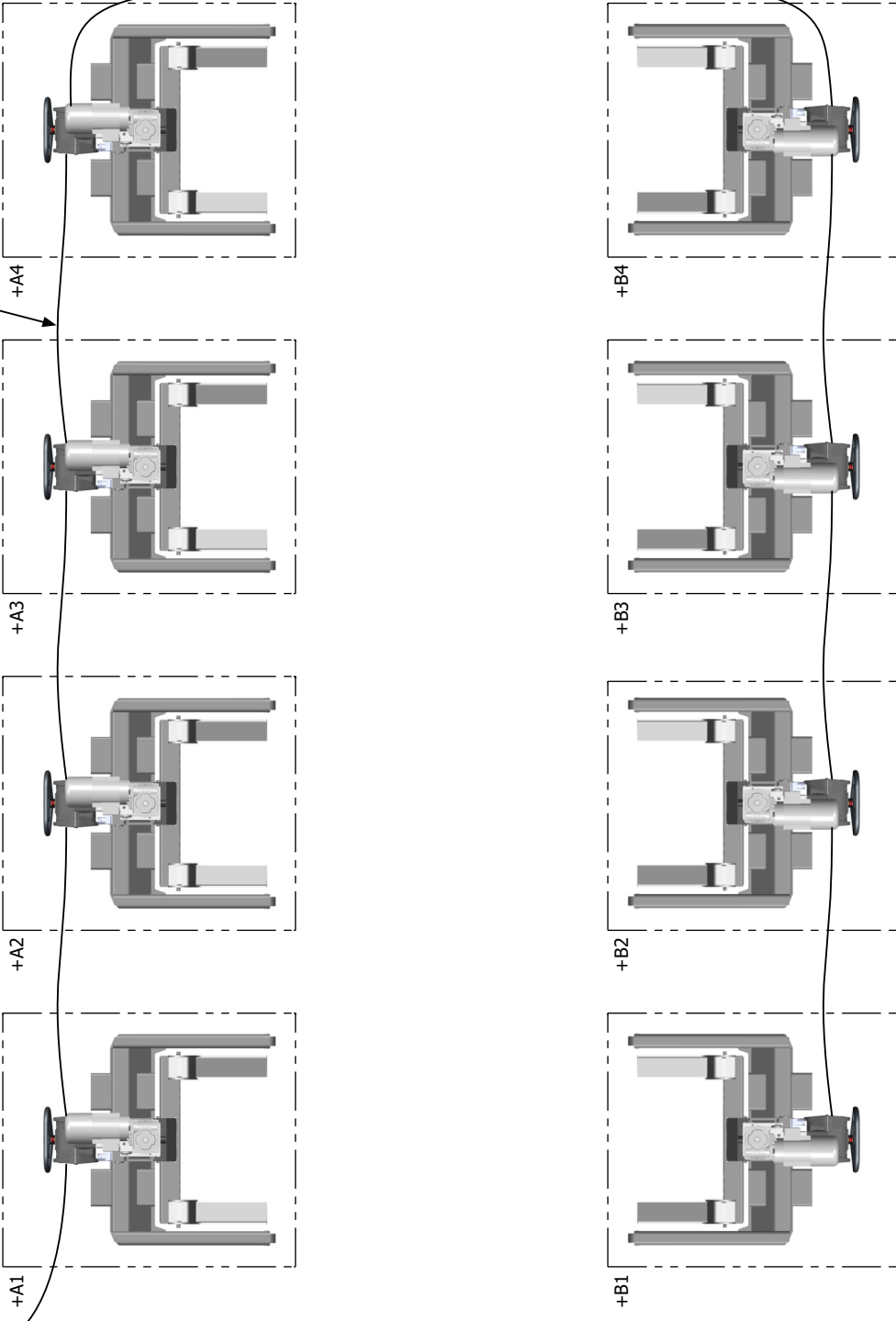



plant A

plant B

Cable for charging and for data communication

Cable for charging and for data communication

8+8 Connecting cable
10m



Charging/ Backup IN 8+8 data connection Charging/ Backup OUT

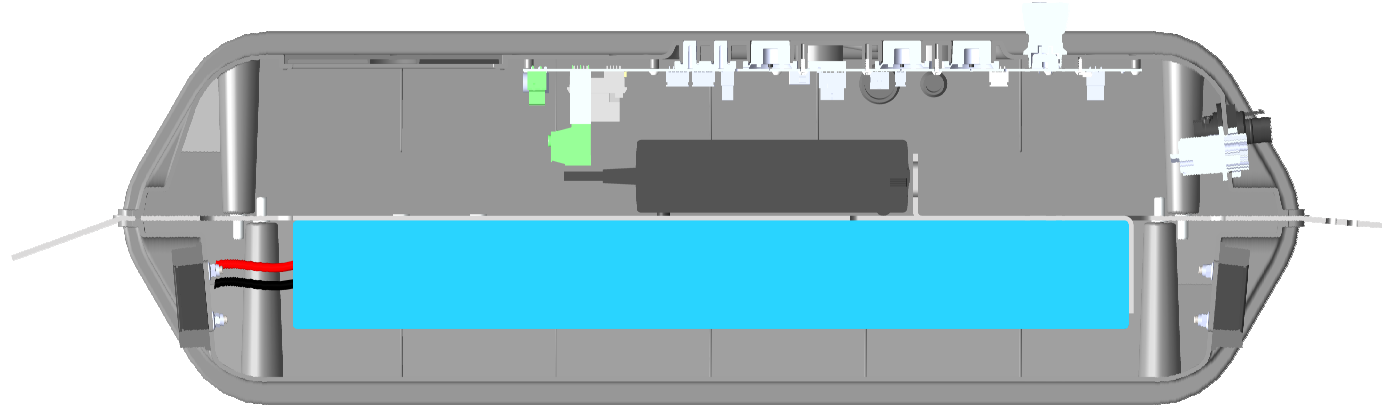
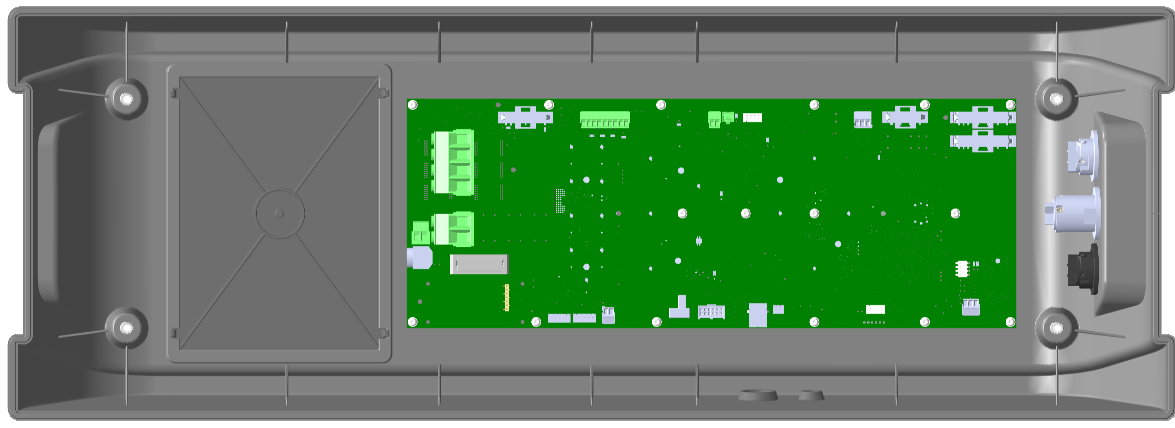

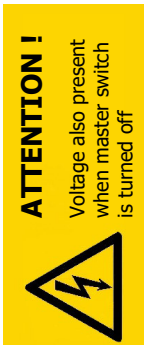
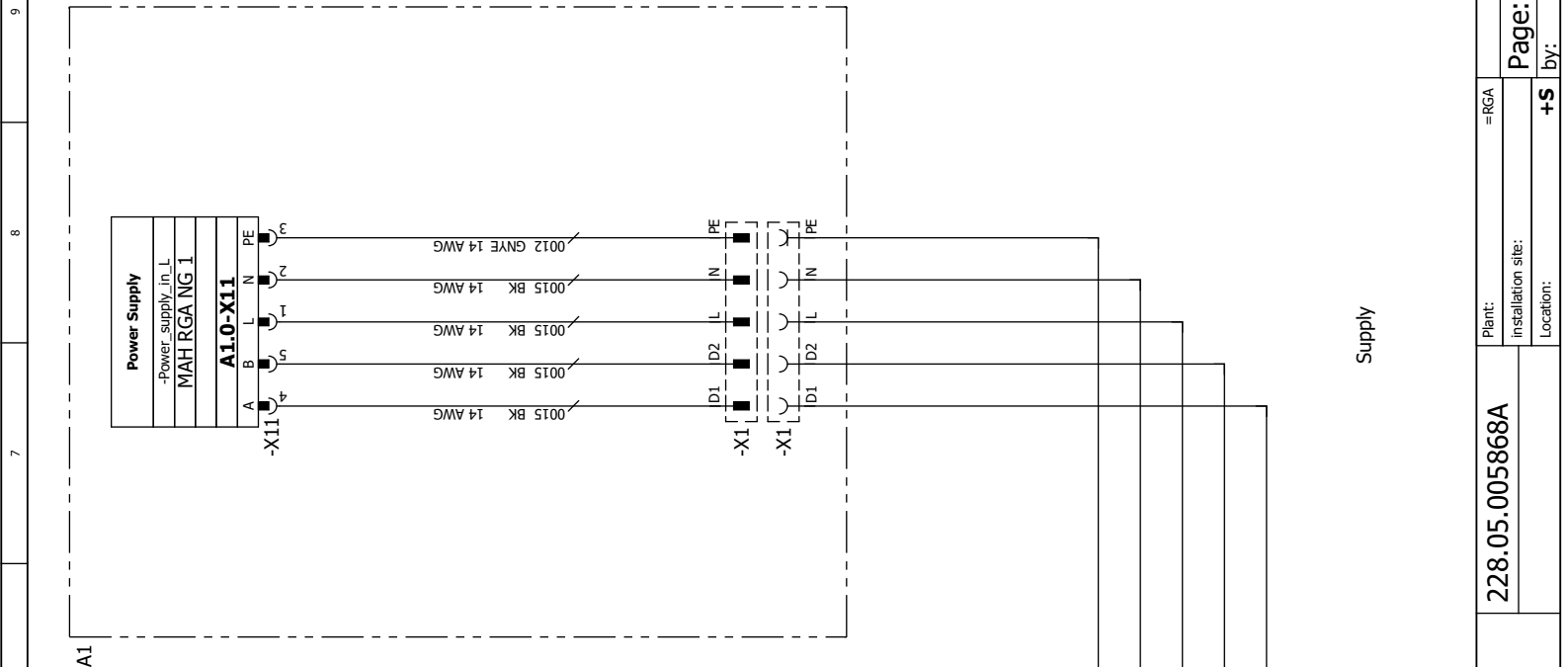

Voltage: **1x110/230V, N, PE, 50/60Hz**
 Fuse protection by the building contractor: **B 16A + RCD(30mA)**

0	1	2	3	4	5	6	7	8	9
---	---	---	---	---	---	---	---	---	---

Grounding Post
-PE
MAH RGA NG 1
/12,8
A1.0-X23
PE
-X23

PE

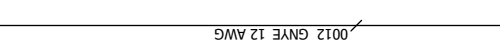

0012 GNYE 12 AWG

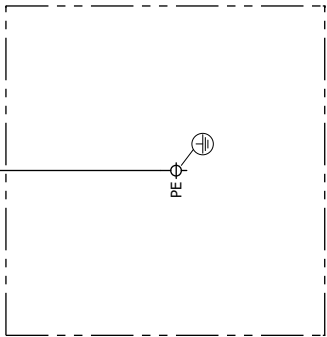

+A

Grounding Post

-A1.0

Board MAH RGA NG 1

X5:	1	+48V_charger	X3:	1	+48V_battery
	2	-GND_charger		2	-GND_battery
X6:	1	+48_1_charger	X1:	1	-Motor
	2	-GND_1_charger		2	-Motor_L2
	3	-GND_2_charger		3	-Motor_L3
	4	+48_2_charger		4	-Motor_PE
	5	-PE_charger		5	-Motor
-X20:	1	-TXD_wireless	-X2:	1	+37V_brake
	2	-RXD_wireless		2	-GND_brake
	3	-GND_wireless		3	+12V_temperature_switch
	4	+5V_wireless		4	-_temperature_switch
	5	-GND_wireless	X9:	1	-signal_limit_switch
	6	-GND_wireless		2	+8V_limit_switch
	7	-GND_wireless		3	-signal_safety_switch
X19:	1	+24V_Display		4	+8V_safety_switch
	2	-GND_Display		5	-signal_load_switch
	3	-RS232-TXD_Display		6	+8V_load_switch
	4	-RS232-RXD_Display		7	-latch_+
	5	-RS232-GND_Display		8	-latch_
X21:	1	+24VDC_buzzer		9	-latch_PE
	2	-GND_buzzer	X8:	1	-signal_pulse_generator
X21:	1	+24V_NFC		2	+8V_pulse_generator
	2	-GND_NFC	X7:	1	-signal_pulse_generator
	3	-RS232-TXD_NFC		2	+8V_pulse_generator
	4	-RS232-RXD_NFC	X4:	1	-BMS_GND
	5	-RS232-GND_NFC		2	-BMS_RS232-RXD
X13:	1	+24VDC_buzzer		3	-BMS_RS232-TXD
	2	-GND_buzzer		4	+24V_160mA-BMS
X15:	1	-emergency_stop_OUT1	X23:	1	-PE
	2	-emergency_stop_IN1		2	-PE
	3	-emergency_stop_OUT2	X17:	1	-SYNC_RS232-TXD
	4	-emergency_stop_IN2		2	-SYNC_RS232-RXD
	5	-button_up_external_in1		3	-SYNC_RS232-GND
	6	-button_up_external_in2	X10:	1	-charger_L1-out
	7	-button_down_external_in1		2	-charger_N-out
	8	-button_down_external_in2		3	-charger_PE-out
	9	-LED_error	X11:	1	-Power_supply_in_L
	10	-LED_button_up		2	-Power_supply_in_N
	11	-LED_button_down		3	-Power_supply_in_PE
	12	-GND_remote_control		4	-Power_supply_in_RS485-A
X18:	1	-VBUS_USB		5	-Power_supply_in_RS485-B
	2	-D_USB	X12:	1	-Power_supply_out_L1
	3	+_USB_D		2	-Power_supply_out_N
	4	-GND_USB		3	-Power_supply_out_PE
X33:	1	-signal_temp_battery		4	-Power_supply_in_RS485-A
	2	-GND_temp_battery		5	-Power_supply_in_RS485-B
X30:	1	+3.3V_Debug	X25:	1	-brake_resistor_+
	2	-RXD_Debug		2	-brake_resistor_
	3	-TXD_Debug			
	4	-GND_Debug			
X14:	1	-signal_4-20mA_weighing_machine			
	2	-GND_weighing_machine			
	3	+12V_weighing_machine			

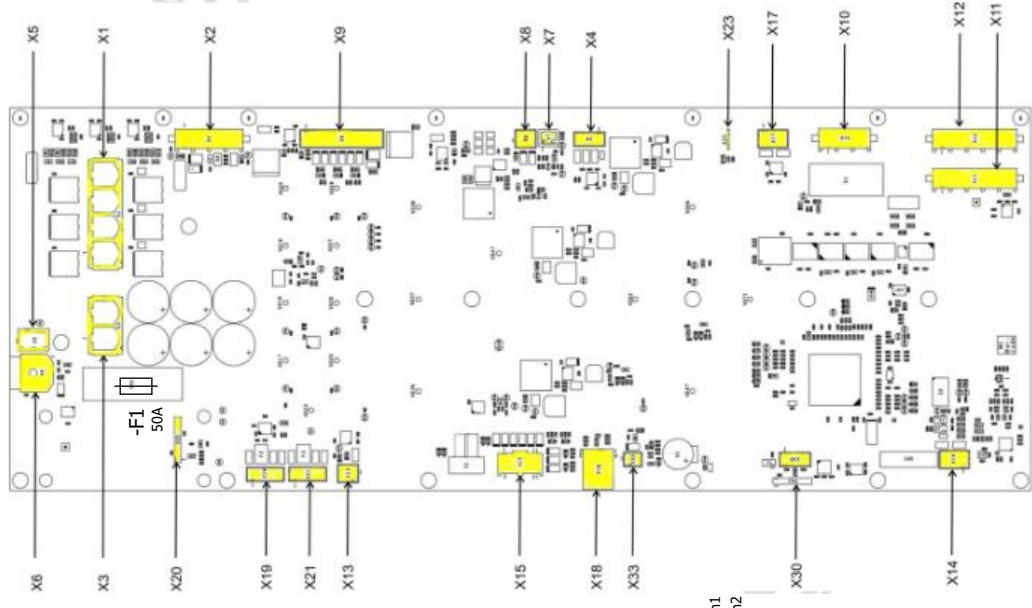
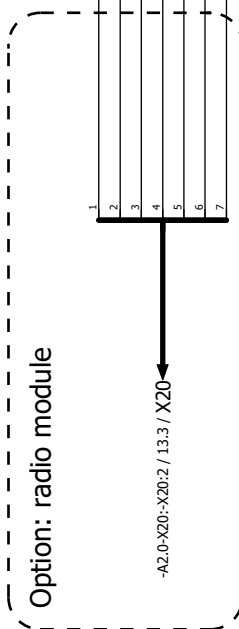

X3:	1	+48V_battery	X17:	1	-SYNC_RS232-TXD
	2	-GND_battery		2	-SYNC_RS232-RXD
	3	+48V_battery		3	-SYNC_RS232-GND
X1:	1	-Motor	X10:	1	-charger_L1-out
	2	-Motor_L2		2	-charger_N-out
	3	-Motor_L3		3	-charger_PE-out
	4	-Motor	X11:	1	-Power_supply_in_L
	5	-Motor		2	-Power_supply_in_N
	6	-Motor		3	-Power_supply_in_PE
	7	-Motor		4	-Power_supply_in_RS485-A
	8	-Motor		5	-Power_supply_in_RS485-B
-X2:	1	+37V_brake	X12:	1	-Power_supply_out_L1
	2	-GND_brake		2	-Power_supply_out_N
	3	+12V_temperature_switch		3	-Power_supply_out_PE
	4	-_temperature_switch		4	-Power_supply_in_RS485-A
	5	-signal_limit_switch		5	-Power_supply_in_RS485-B
	6	+8V_limit_switch			
	7	-signal_safety_switch			
	8	+8V_safety_switch			
	9	-signal_load_switch			
	10	+8V_load_switch			
	11	-latch_+			
	12	-latch_			
	13	-latch_PE			
X8:	1	-signal_pulse_generator	X23:	1	-PE
	2	+8V_pulse_generator		2	-PE
X7:	1	-signal_pulse_generator	X17:	1	-SYNC_RS232-TXD
	2	+8V_pulse_generator		2	-SYNC_RS232-RXD
	3	-signal_pulse_generator		3	-SYNC_RS232-GND
X4:	1	-BMS_GND	X10:	1	-charger_L1-out
	2	-BMS_RS232-RXD		2	-charger_N-out
	3	-BMS_RS232-TXD		3	-charger_PE-out
	4	+24V_160mA-BMS	X11:	1	-Power_supply_in_L
X23:	1	-PE		2	-Power_supply_in_N
	2	-PE		3	-Power_supply_in_PE
X17:	1	-SYNC_RS232-TXD		4	-Power_supply_in_RS485-A
	2	-SYNC_RS232-RXD		5	-Power_supply_in_RS485-B
	3	-SYNC_RS232-GND	X12:	1	-Power_supply_out_L1
X10:	1	-charger_L1-out		2	-Power_supply_out_N
	2	-charger_N-out		3	-Power_supply_out_PE
	3	-charger_PE-out		4	-Power_supply_in_RS485-A
X11:	1	-Power_supply_in_L		5	-Power_supply_in_RS485-B
	2	-Power_supply_in_N			
	3	-Power_supply_in_PE			
	4	-Power_supply_in_RS485-A			
	5	-Power_supply_in_RS485-B			
X12:	1	-Power_supply_out_L1			
	2	-Power_supply_out_N			
	3	-Power_supply_out_PE			
	4	-Power_supply_in_RS485-A			
	5	-Power_supply_in_RS485-B			
X25:	1	-brake_resistor_+			
	2	-brake_resistor_			

Option: radio module

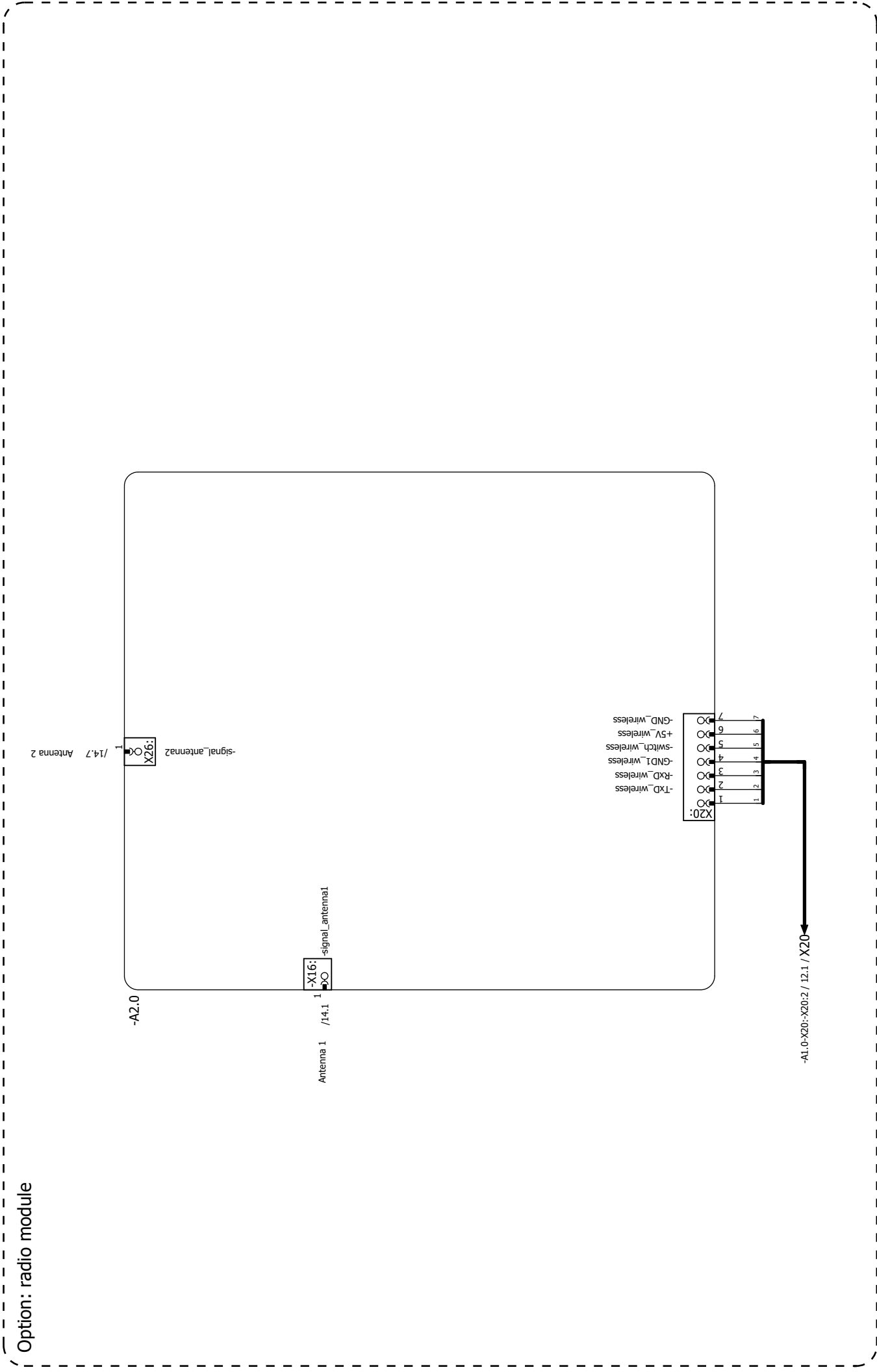

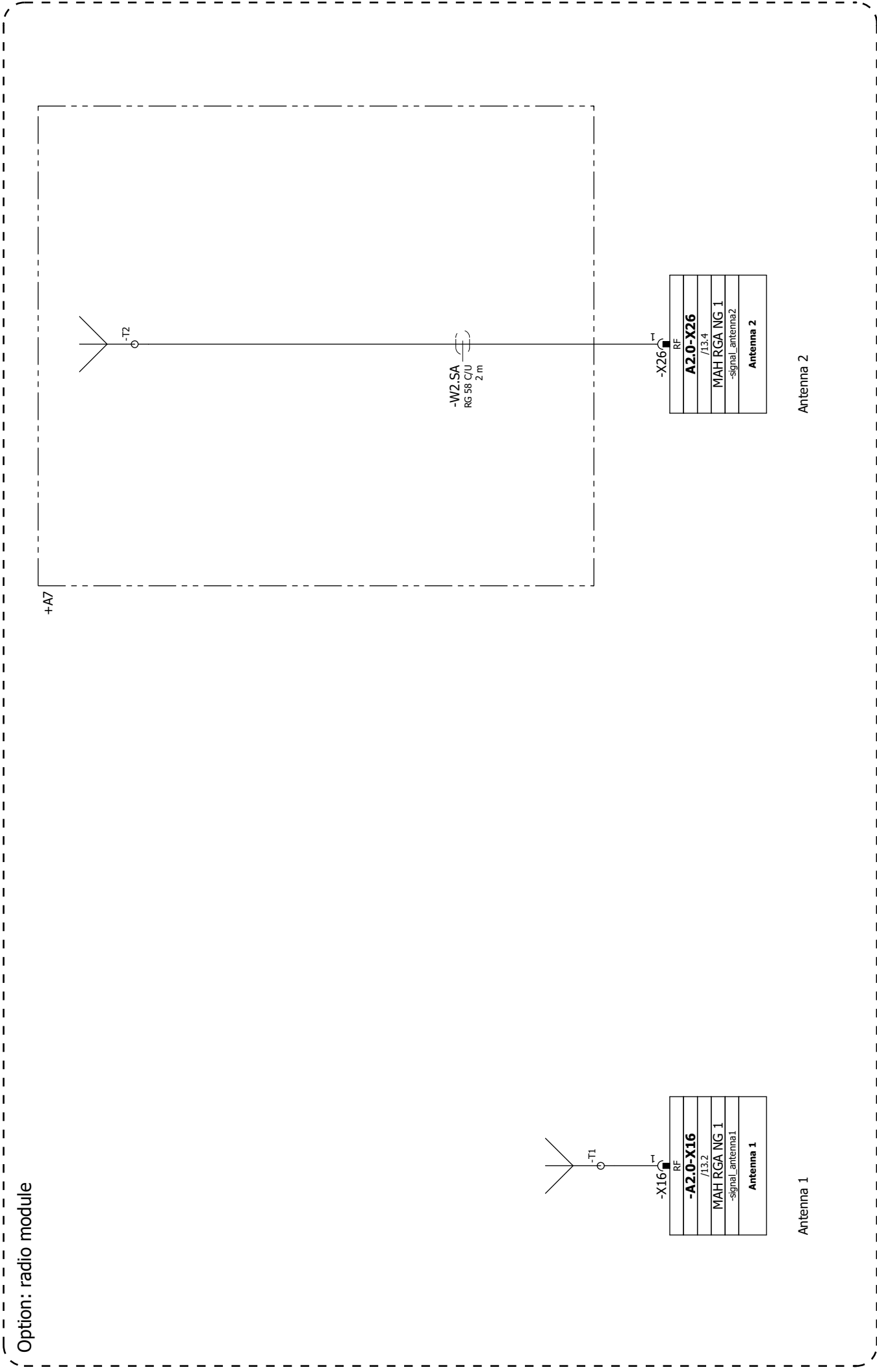

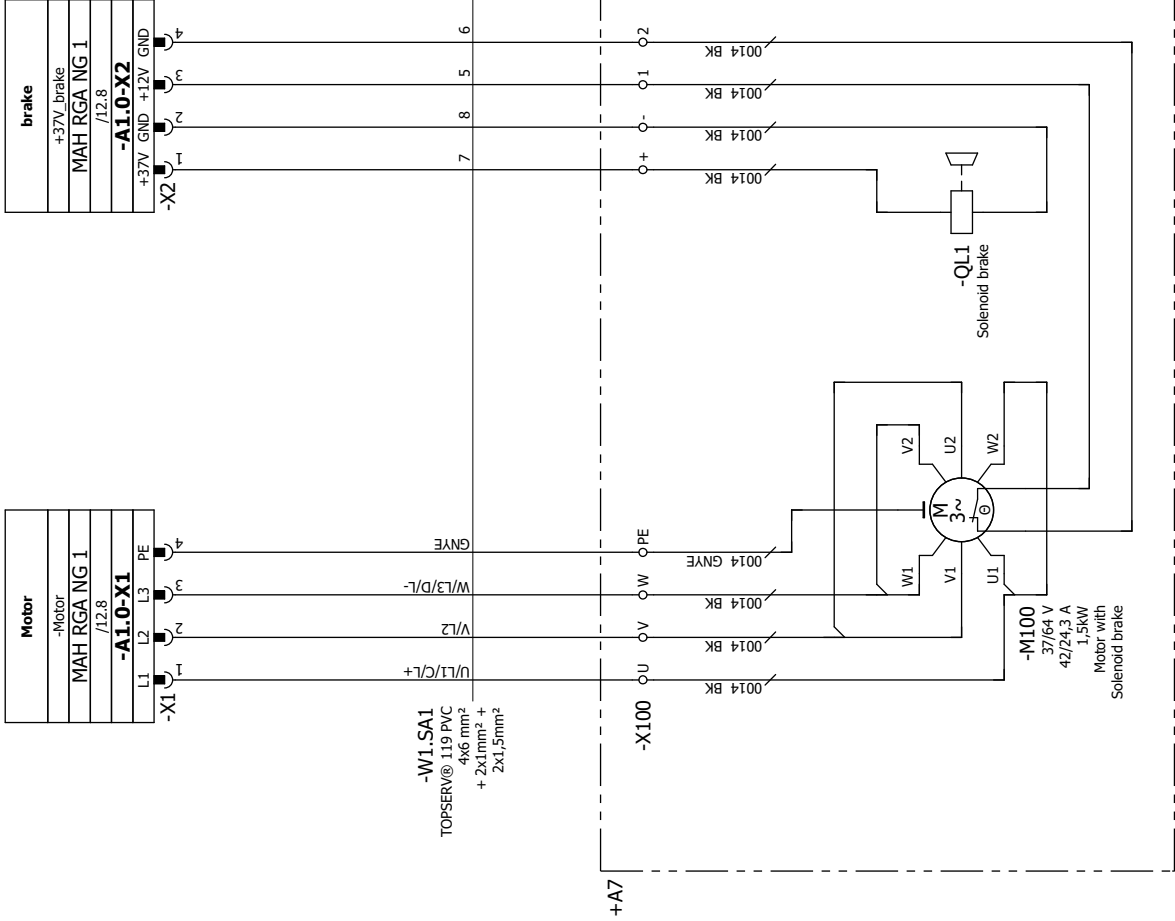

Motor / brake / temperature switch

Motor

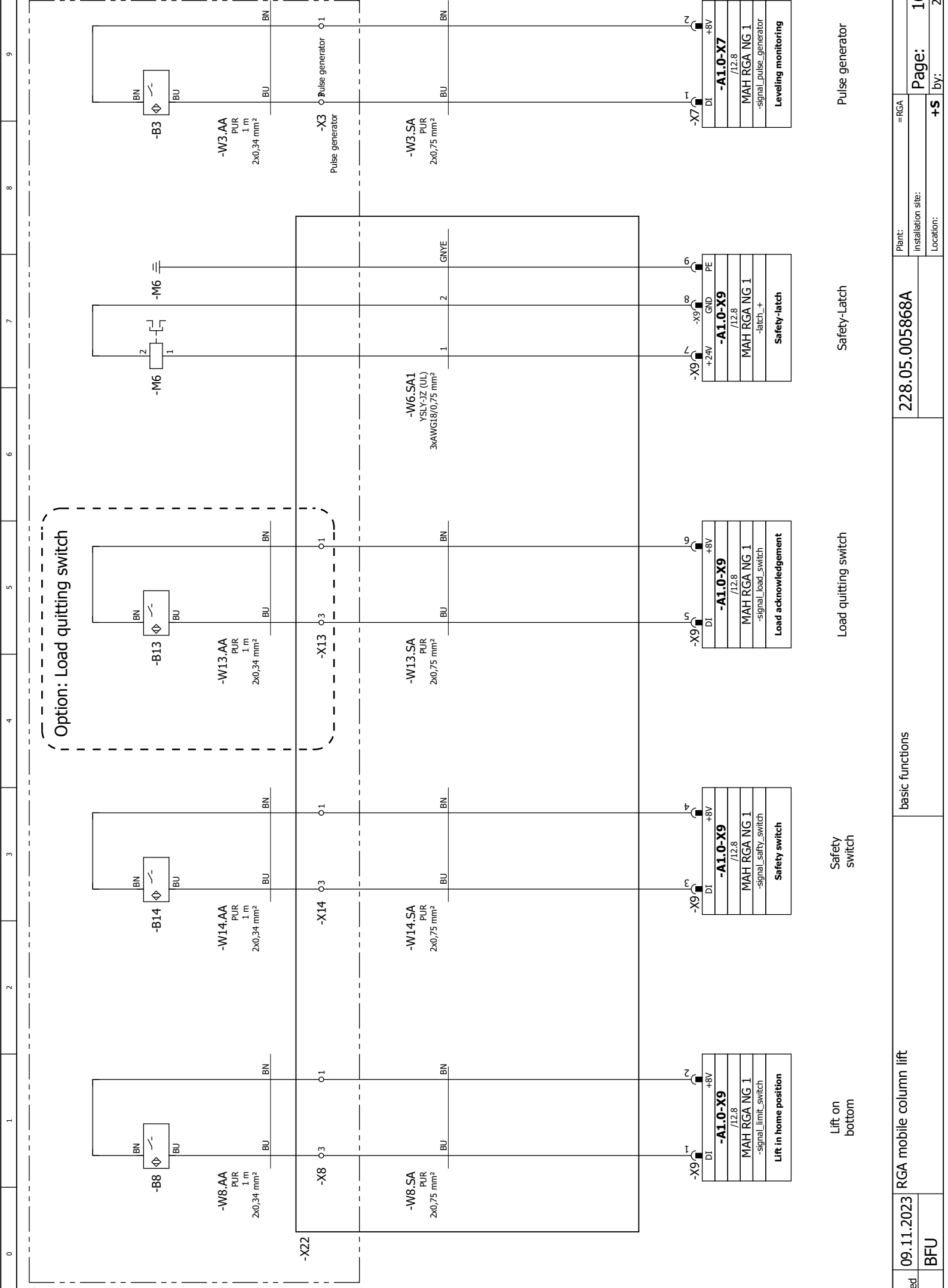

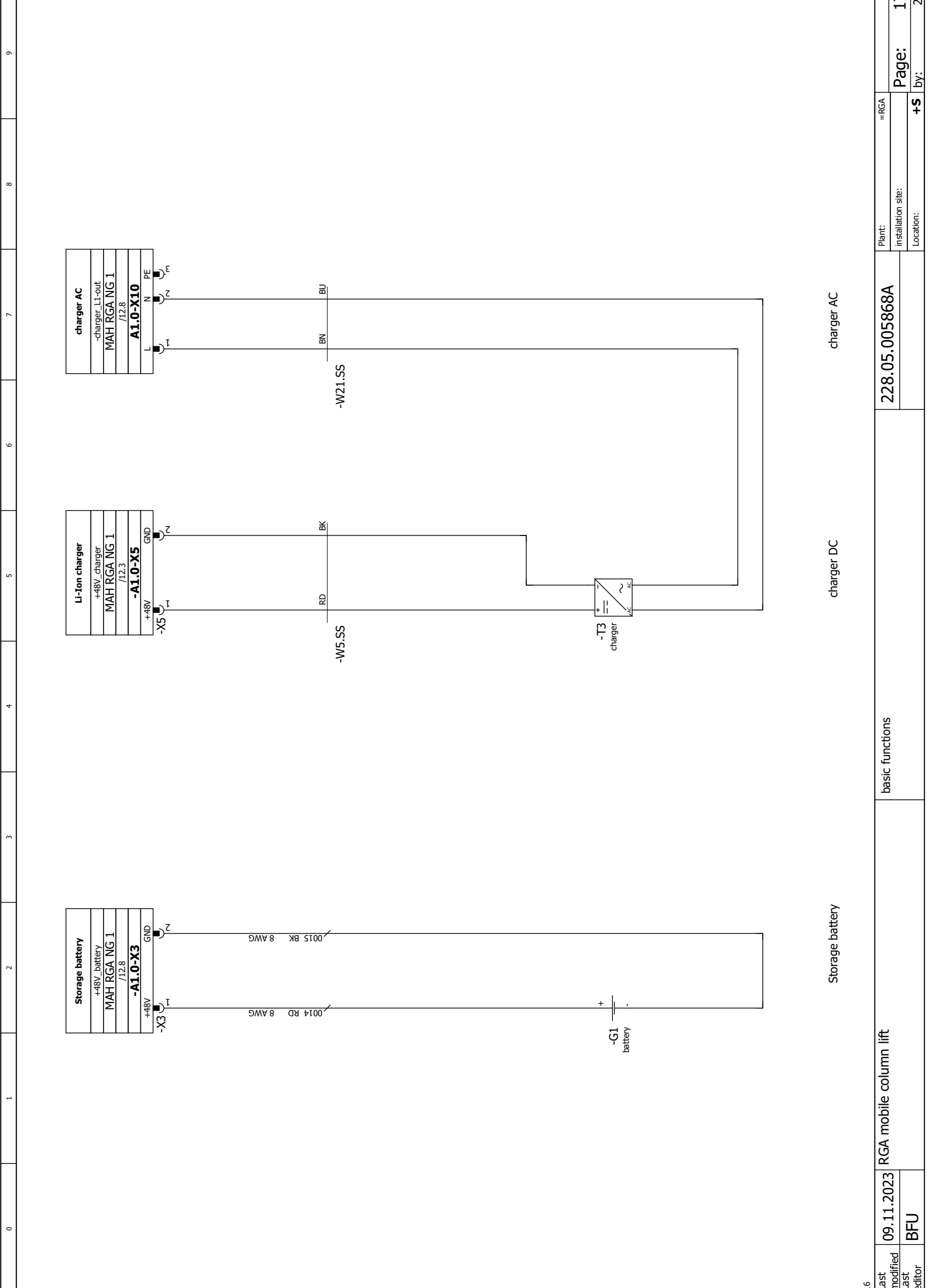

Storage battery

charger DC

charger AC

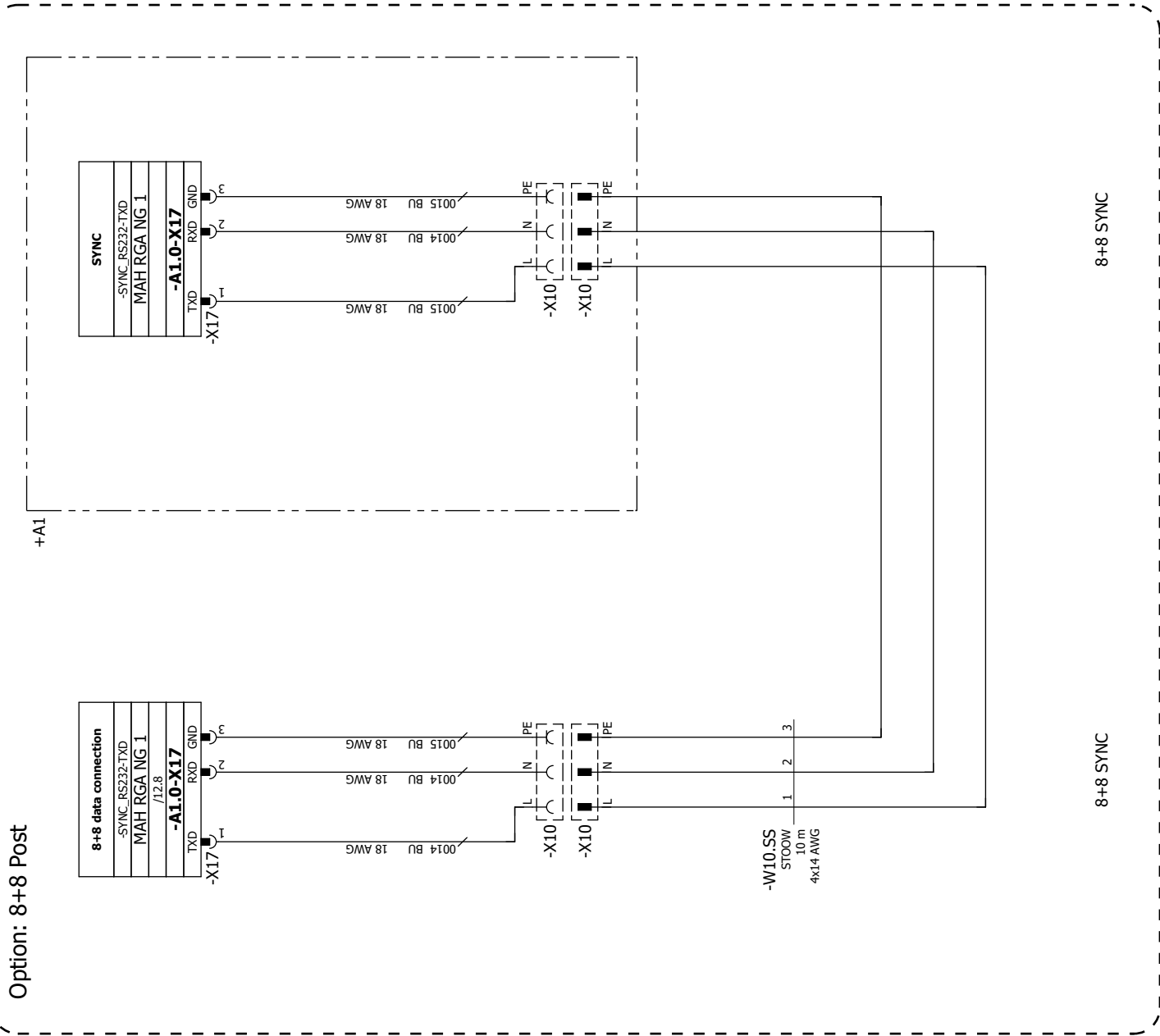

Cable diagram

KABEL_MAH_SERIE_01

<i>Cable name</i>	W1.AS	<i>cable type</i>	<i>no. of conductors</i>		<i>cross-section</i>	2,5	<i>cable length</i>	10	<i>part number</i>	1405139
function text	/ Page.Path	Target designation from	Connection point	conductor	Target designation to	Connection point	/ Page.Path	function text		
=	=RGA+S/10.1	+S-X1	L	BN	+S-XD1	L	=RGA+S/10.1	Netzanschluss		
=	=RGA+S/10.1	+S-X1	N	BU	+S-XD1	N	=RGA+S/10.1	=		
=	=RGA+S/10.1	+S-X1	PE	GNYE	+S-XD1	PE	=RGA+S/10.1	=		

<i>Cable name</i>	W1.SA1	<i>cable type</i>	TOPSERV@ 119 PVC		<i>cross-section</i>	6	<i>cable length</i>	<i>part number</i>	1407486
function text	/ Page.Path	Target designation from	Connection point	conductor	Target designation to	Connection point	/ Page.Path	function text	
temperature	=RGA+S/15.5	+A7-X100	1	5	+S-A1.0-X2	-X2:3	=RGA+S/15.5	temperature switch	
=	=RGA+S/15.6	+A7-X100	2	6	+S-A1.0-X2	-X2:4	=RGA+S/15.6	=	
brake	=RGA+S/15.5	+A7-X100	+	7	+S-A1.0-X2	-X2:1	=RGA+S/15.5	brake	
=	=RGA+S/15.5	+A7-X100	-	8	+S-A1.0-X2	-X2:2	=RGA+S/15.5	=	
Motor	=RGA+S/15.3	+A7-X100	PE	GNYE	+S-A1.0-X1	-X1:4	=RGA+S/15.3	Motor	
=	=RGA+S/15.3	+A7-X100	U	U/L1/C/L+	+S-A1.0-X1	-X1:1	=RGA+S/15.3	=	
=	=RGA+S/15.3	+A7-X100	V	V/L2	+S-A1.0-X1	-X1:2	=RGA+S/15.3	=	
=	=RGA+S/15.3	+A7-X100	W	W/L3/D/L-	+S-A1.0-X1	-X1:3	=RGA+S/15.3	=	

<i>Cable name</i>	W1.SS	<i>cable type</i>	H07 RN-F		<i>cross-section</i>	2,5	<i>cable length</i>	<i>part number</i>	1405136
function text	/ Page.Path	Target designation from	Connection point	conductor	Target designation to	Connection point	/ Page.Path	function text	
Verbindungskabel Laden/Backupdatenverbindung	=RGA+S/10.4	+S-X2	D2	BK	+A1-X1	D2	=RGA+S/10.7	Verbindungskabel Laden/Backupdatenverbindung	
=	=RGA+S/10.4	+S-X2	L	BN	+A1-X1	L	=RGA+S/10.7	=	
=	=RGA+S/10.4	+S-X2	N	BU	+A1-X1	N	=RGA+S/10.7	=	
=	=RGA+S/10.4	+S-X2	PE	GNYE	+A1-X1	PE	=RGA+S/10.7	=	
=	=RGA+S/10.4	+S-X2	D1	GY	+A1-X1	D1	=RGA+S/10.7	=	

Cable diagram

KABEL_MAHASERIE_01

<i>Cable name</i>	W2.SA	<i>cable type</i>	RG 58 C/U	<i>no. of conductors</i>	<i>cross-section</i>	<i>cable length</i>	2	<i>part number</i>	1407481
	function text	/ Page.Path	Target designation from	Conductor	Target designation to	Connection point	/ Page.Path	function text	
Antenna 2		=RGA+S/14.7	+S-A2.0-X26	-X26:1	+A7-T2	=RGA+S/14.7	Antenna 2		

<i>Cable name</i>	W3.AA	<i>cable type</i>	PUR	<i>no. of conductors</i>	<i>cross-section 0,34</i>	<i>cable length</i>	1	<i>part number</i>	1401327
	function text	/ Page.Path	Target designation from	Conductor	Target designation to	Connection point	/ Page.Path	function text	
Pulse generator		=RGA+S/16.9	+A7-X3	1	+A7-B3	BN	=RGA+S/16.9		
=		=RGA+S/16.9	+A7-X3	3	+A7-B3	BU	=RGA+S/16.9		

<i>Cable name</i>	W3.SA	<i>cable type</i>	PUR	<i>no. of conductors</i>	<i>cross-section 0,75</i>	<i>cable length</i>	<i>part number</i>	1407477
	function text	/ Page.Path	Target designation from	Conductor	Target designation to	Connection point	/ Page.Path	function text
Pulse generator		=RGA+S/16.9	+A7-X3	1	+S-A1.0-X7	-X7:2	=RGA+S/16.9	Leveling monitoring
=		=RGA+S/16.9	+A7-X3	3	+S-A1.0-X7	-X7:1	=RGA+S/16.9	=

Cable diagram

KABEL_MAHASERIE_01

<i>Cable name</i>	W5.SS	<i>cable type</i>	<i>no. of conductors</i>		<i>cross-section</i>	<i>cable length</i>		<i>part number</i>
function text	/ Page.Path	Target designation from	Connection point	conductor	Target designation to	Connection point	/ Page.Path	function text
Li-Ion charger	=RGA+S/17.5	+S-A1.0>X5	-X5:2	BK	+S-T3	=RGA+S/17.5	charger	
charger AC	=RGA+S/18.7	+S-A1.0>X10	3	GNYE	+S-A1.0>X6	-X6:5	AGM charger	
Li-Ion charger	=RGA+S/17.5	+S-A1.0>X5	-X5:1	RD	+S-T3	=RGA+S/17.5	charger	

<i>Cable name</i>	W8.AA	<i>cable type</i>	PUR	<i>no. of conductors</i>	<i>cross-section</i>	<i>cable length</i>		<i>part number</i>
function text	/ Page.Path	Target designation from	Connection point	conductor	Target designation to	Connection point	/ Page.Path	function text
Lift on bottom	=RGA+S/16.1	+A7>X8	1	BN	+A7-B8	BN	=RGA+S/16.1	
=	=RGA+S/16.1	+A7>X8	3	BU	+A7-B8	BU	=RGA+S/16.1	

<i>Cable name</i>	W10.SS	<i>cable type</i>	STOOW	<i>no. of conductors</i>	<i>cross-section</i>	<i>cable length</i>		<i>part number</i>
function text	/ Page.Path	Target designation from	Connection point	conductor	Target designation to	Connection point	/ Page.Path	function text
8+8 SYNC	=RGA+S/19.1	+S-X10	L	1	+A1>X10	L	=RGA+S/19.4	8+8 SYNC
=	=RGA+S/19.1	+S-X10	N	2	+A1>X10	N	=RGA+S/19.4	=
=	=RGA+S/19.1	+S-X10	PE	3	+A1>X10	PE	=RGA+S/19.4	=

<i>Cable name</i>	W13.AA	<i>cable type</i>	PUR	<i>no. of conductors</i>	<i>cross-section</i>	<i>cable length</i>		<i>part number</i>
function text	/ Page.Path	Target designation from	Connection point	conductor	Target designation to	Connection point	/ Page.Path	function text
Load quitting switch	=RGA+S/16.5	+A7>X13	1	BN	+A7-B13	BN	=RGA+S/16.5	
Safety switch	=RGA+S/16.5	+A7>X13	3	BU	+A7-B13	BU	=RGA+S/16.5	

<i>Cable name</i>	W14.AA	<i>cable type</i>	PUR	<i>no. of conductors</i>	<i>cross-section</i>	<i>cable length</i>		<i>part number</i>
function text	/ Page.Path	Target designation from	Connection point	conductor	Target designation to	Connection point	/ Page.Path	function text
Safety switch	=RGA+S/16.3	+A7>X14	1	BN	+A7-B14	BN	=RGA+S/16.3	
=	=RGA+S/16.3	+A7>X14	3	BU	+A7-B14	BU	=RGA+S/16.3	

Parts list

ARTIST_MAHASERIE_01

<i>Part No.</i>	<i>Quantity</i>	<i>designation</i>	<i>Type number</i> <i>Order number</i>	<i>manufacturer</i> <i>supplier</i>	<i>MAHA-Part No.</i>
+S-A1.0 =RGA+S/12.3	1	board MCL wireless	MAH RGA NG 1	Knestel-Electronic Knestel-Electronic	1406514
+S-A1.0 =RGA+S/12.3	1	board MCL wired	MAH RGA NG 2	Knestel-Electronic Knestel-Electronic	1408573
+S-A1.0-FI =RGA+S/12.5	1 piece	MAXI fuse	343.435-58V 1407489	ESKA ESKA	1407489
+S-G1 =RGA+S/17.2	1 piece	Li-Ion battery	1405133	Maschinenbau Haldenwang Maschinenbau Haldenwang	1405133
+S-T1 =RGA+S/14.1	1 Piece	Antenna 0 dbi	1407492	Maschinenbau Haldenwang Maschinenbau Haldenwang	1407492
+S-T3 =RGA+S/17.5	1 piece	Li-Ion charger	1405134	Fuyuang Fuyuang	1405134
+S-T3 =RGA+S/17.5	1 piece	AGM charger	1402844	Meanwell Meanwell	1402844
+S-X1 =RGA+S/10.1	1	Cable harness Charg. cable RGA 01	1405038	Maschinenbau Haldenwang Maschinenbau Haldenwang	1405038
+S-X2 =RGA+S/10.4	1	Cable harness Charg. cable RGA 02	1405039	Maschinenbau Haldenwang Maschinenbau Haldenwang	1405039
+S-X10 =RGA+S/19.1	1	Cable harness Connect. RGA 8+8 01	1405153	Maschinenbau Haldenwang Maschinenbau Haldenwang	1405153
+S-XD1 =RGA+S/10.1	1	cable assembly EU connection cable	1405139	Maschinenbau Haldenwang Maschinenbau Haldenwang	1405139
+S-XD1 =RGA+S/10.1	1	cable assembly Connection cable US	1405140	Maschinenbau Haldenwang Maschinenbau Haldenwang	1405140
+S-XD1 =RGA+S/10.1	1	cable assembly UK connection cable	1405145	Maschinenbau Haldenwang Maschinenbau Haldenwang	1405145
+S-XD1 =RGA+S/10.1	1	cable assembly Connection cable Australia	1405146	Maschinenbau Haldenwang Maschinenbau Haldenwang	1405146
+S-XD1 =RGA+S/10.1	1	cable assembly Connection cable swiss	1405182	Maschinenbau Haldenwang Maschinenbau Haldenwang	1405182
+S-XD1 =RGA+S/10.1	1	cable assembly Universal connection cable without plug	1405147	Maschinenbau Haldenwang Maschinenbau Haldenwang	1405147
+A1-X1 =RGA+S/10.7	1	cable assembly Connection cable/charging cable 10m	1405136	Maschinenbau Haldenwang Maschinenbau Haldenwang	1405136
+A1-X1 =RGA+S/10.7	1	cable assembly Connection cable/charging cable 15m	1405137	Maschinenbau Haldenwang Maschinenbau Haldenwang	1405137
+A1-X1 =RGA+S/10.7	1	cable assembly Connection cable/charging cable 20m	1405138	Maschinenbau Haldenwang Maschinenbau Haldenwang	1405138
+A1-X10 =RGA+S/19.4	1	cable assembly Connection cable 8+8 10m	1405154	Maschinenbau Haldenwang Maschinenbau Haldenwang	1405154
+A-PE =RGA+S/11.2	1	cable assembly Grounding cable AWG12	1407474	Maschinenbau Haldenwang Maschinenbau Haldenwang	1407474
+A7-B3 =RGA+S/16.9	1 Piece	sensor Coupling	NCB4-12GM40-NO NCB4-12GM40-NO	Pepperl + Fuchs Pepperl + Fuchs	1401327

Parts list

ARTIST_MAHHA_SERIE_01

<i>RKZ</i> <i>Placement</i>	<i>Quantity</i> <i>ME</i>	<i>designation</i>	<i>Type number</i> <i>Order number</i>	<i>manufacturer</i> <i>supplier</i>	<i>MAHA-Part No.</i>
+A7-B8 =RGA+S/16.1	1 Piece	sensor Coupling	NCB4-12GM40-N0 NCB4-12GM40-N0	Pepperl + Fuchs Pepperl + Fuchs	1401327
+A7-B13 =RGA+S/16.5	1 Piece	sensor Coupling	NCB4-12GM40-N0 NCB4-12GM40-N0	Pepperl + Fuchs Pepperl + Fuchs	1401327
+A7-B14 =RGA+S/16.3	1 Piece	sensor Coupling	NCB4-12GM40-N0 NCB4-12GM40-N0	Pepperl + Fuchs Pepperl + Fuchs	1401327
+A7-F2 =RGA+S/18.2	1 piece	MAXI fuse	343.435-58V 1407489	ESKA ESKA	1407489
+A7-F2 =RGA+S/18.2	1	cabl assembly AGM batteries	1407487	Maschinenbau Haldenwang Maschinenbau Haldenwang	1407487
+A7-F3 =RGA+S/18.2	1 piece	MAXI fuse	343.435-58V 1407489	ESKA ESKA	1407489
+A7-G1 =RGA+S/18.2	1 piece	AGM battery	52 0318		1236096
+A7-G2 =RGA+S/18.2	1 piece	AGM battery	52 0318		1236096
+A7-G3 =RGA+S/18.2	1 piece	AGM battery	52 0318		1236096
+A7-G4 =RGA+S/18.2	1 piece	AGM battery	52 0318		1236096
+A7-T2 =RGA+S/14.7	1	cabl assembly Antenne RGA 01	1407481	Maschinenbau Haldenwang Maschinenbau Haldenwang	1407481
+A7-X3 =RGA+S/16.9	1	cabl assembly Extension cabl pulse generator	1407477	Maschinenbau Haldenwang Maschinenbau Haldenwang	1407477
+A7-X22 =RGA+S/16.0	1	cabl assembly Cabl + energy chain	1405003	Maschinenbau Haldenwang Maschinenbau Haldenwang	1405003
+A7-X100 =RGA+S/15.3	1	cabl assembly Motor	1407486	Maschinenbau Haldenwang Maschinenbau Haldenwang	1407486

technical data							
VP 451193 / VP 451191				C_RGA 7.5 UC			
load capacity per column				7500 kg			
motor power per column				1,5 kW			
weight per column				525 kg			
full travel				1700 mm			
lifting height				1800 mm			
column width				180 mm			
frame width				1150 mm			
frame height				131 mm			
total height				2474 mm			
lifting time (load-dependent)				132 s			
lifting time - fast mode (load-dependent)				85 s			
Inner distance of support forks min. - max.				290 mm - 680 mm			
tyre diameter min. - max.				500 mm - 1500 mm			
fork length				380 mm			
lifting cycles at full load (without fast mode)				20			
lifting cycles at partial load (without fast mode, 3500 kg)				34			
safety class				IP 54			
noise emission				< 70 dB(A)			
hertzian stress on wheel (max.)				645 N/mm ²			
surface load floor plate (max.)				< 2 N/mm ²			
power supply				1x 100-240 VAC 50/60Hz; 2 A			
fuse				B 16A RCD (30 mA)			
energy supply (standard)				Lilon 50,4 VDC			
energy supply (option)				AGM 4x 12 VDC			
Schutzvermerk beachten nach DIN ISO 16016		Maßstab 1:15		Materialnummer 1409255		Revision 09	
		Konfigurationstyp		Dokumenttyp		Änderungsnr. Büro 101594 300	
		Benennung C_RGA 7.5 UC - Product Datasheet					
MAHAGROUP		Datum, Prüfer		Dokumentnummer F4900		Version I Blatt A3 von	
Datum, Ersteller 31.10.2023 KBRENNER		Datum, Freigabe 02.11.2023 KBRENNER		alte Materialnummer			

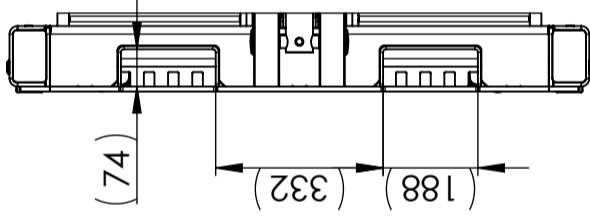
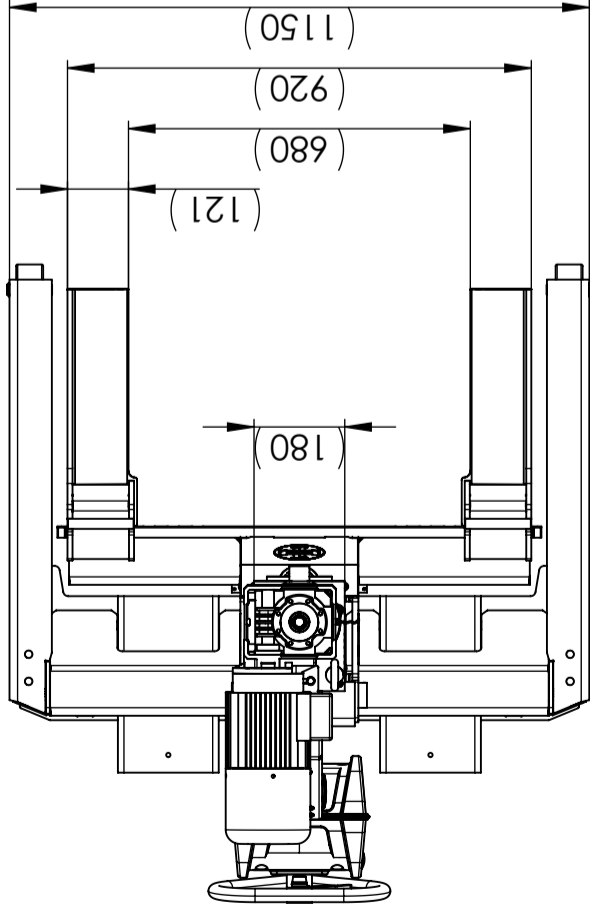
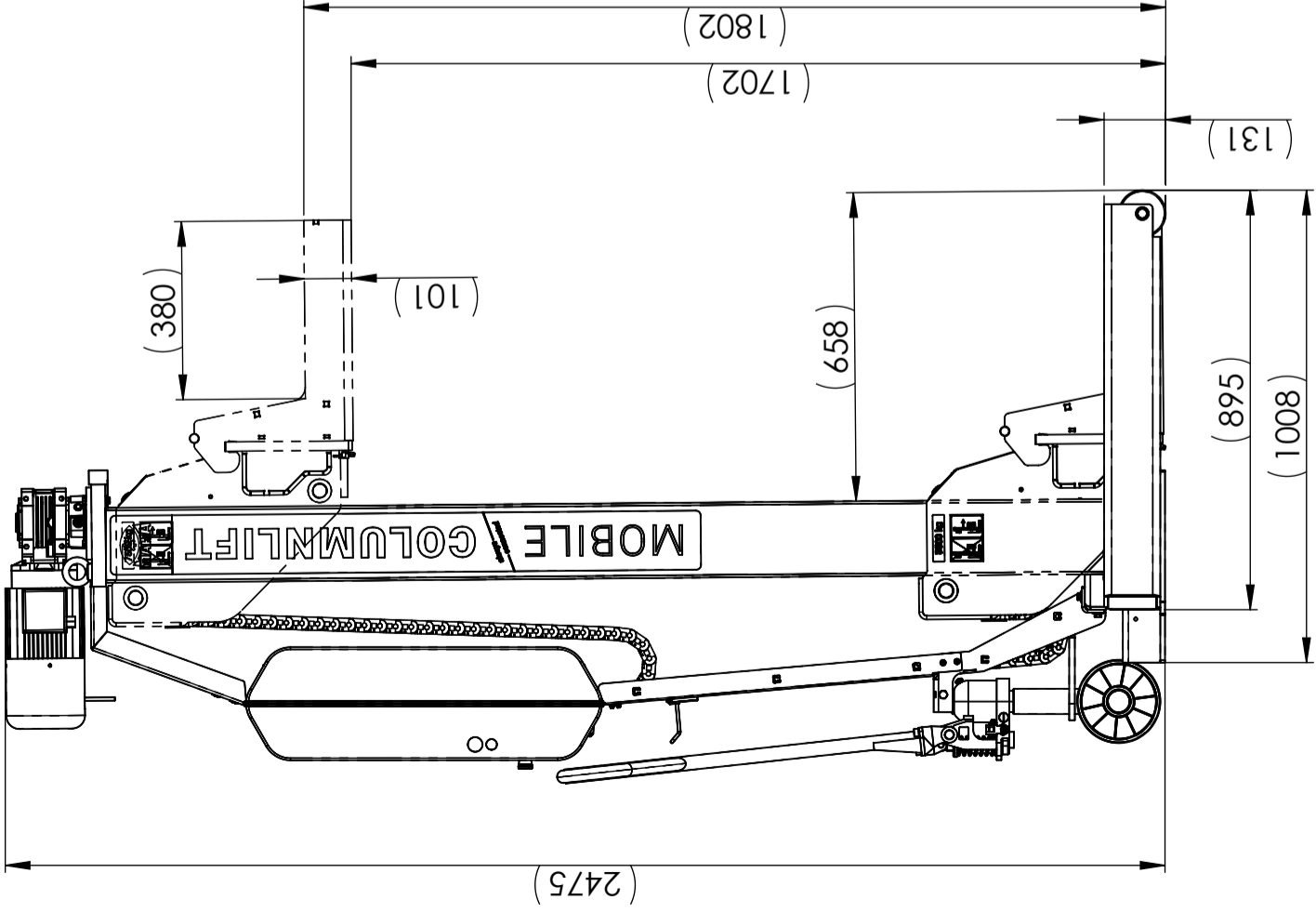

A	B	C	D	E	F
technical data					
VP 451196 / VP 451197		C_RGA 8.5 UC			
load capacity per column	8500 kg				
motor power per column	1,5 kW				
weight per column	525 kg				
full travel	1700 mm				
lifting height	1800 mm				
column width	180 mm				
frame width	1150 mm				
frame height	131 mm				
total height	2474 mm				
lifting time (load-dependent)	140 s				
lifting time - fast mode (load-dependent)	85 s				
Inner distance of support forks min. - max.	290 mm - 680 mm				
tyre diameter min. - max.	500 mm - 1500 mm				
fork length	380 mm				
lifting cycles at full load (without fast mode)	15				
lifting cycles at partial load (without fast mode, 3500 kg)	30				
safety class	IP 54				
noise emission	< 70 dB(A)				
hertzian stress on wheel (max.)	645 N/mm ²				
surface load floor plate (max.)	< 2 N/mm ²				
power supply	1x 100-240 VAC 50/60Hz; 2 A				
fuse	B 16A RCD (30 mA)				
energy supply	Lilon 50,4 VDC				
Schutzvermerk beachten nach DIN ISO 16016		Maßstab 1:15	Materialnummer 1409255	Revision 09	
		Konfigurationstyp	Dokumenttyp	Änderungsnr. 101594	Büro 300
		Benennung C_RGA 8.5 UC - Product Datasheet			
M A H A G R O U P		Dokumentnummer F4901		Version I	Blatt von A3
Datum, Ersteller 31.10.2023 KBRENNER	Datum, Prüfer 02.11.2023 NLASTOVK	Datum, Freigabe 02.11.2023 KBRENNER	alte Materialnummer		

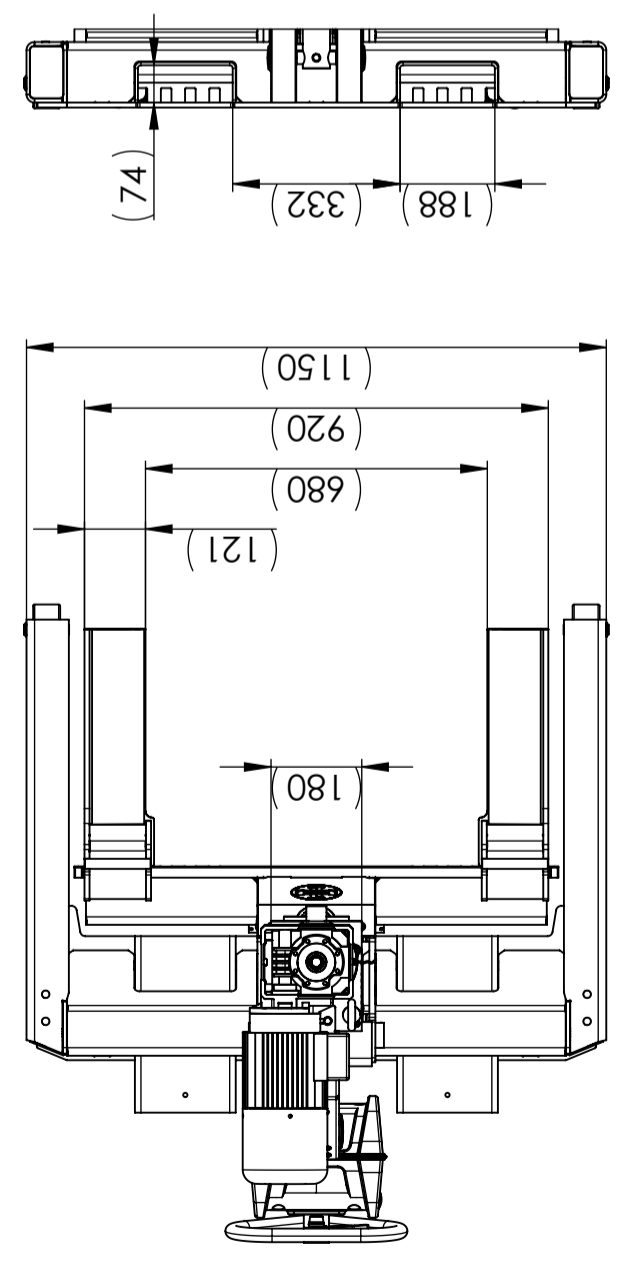
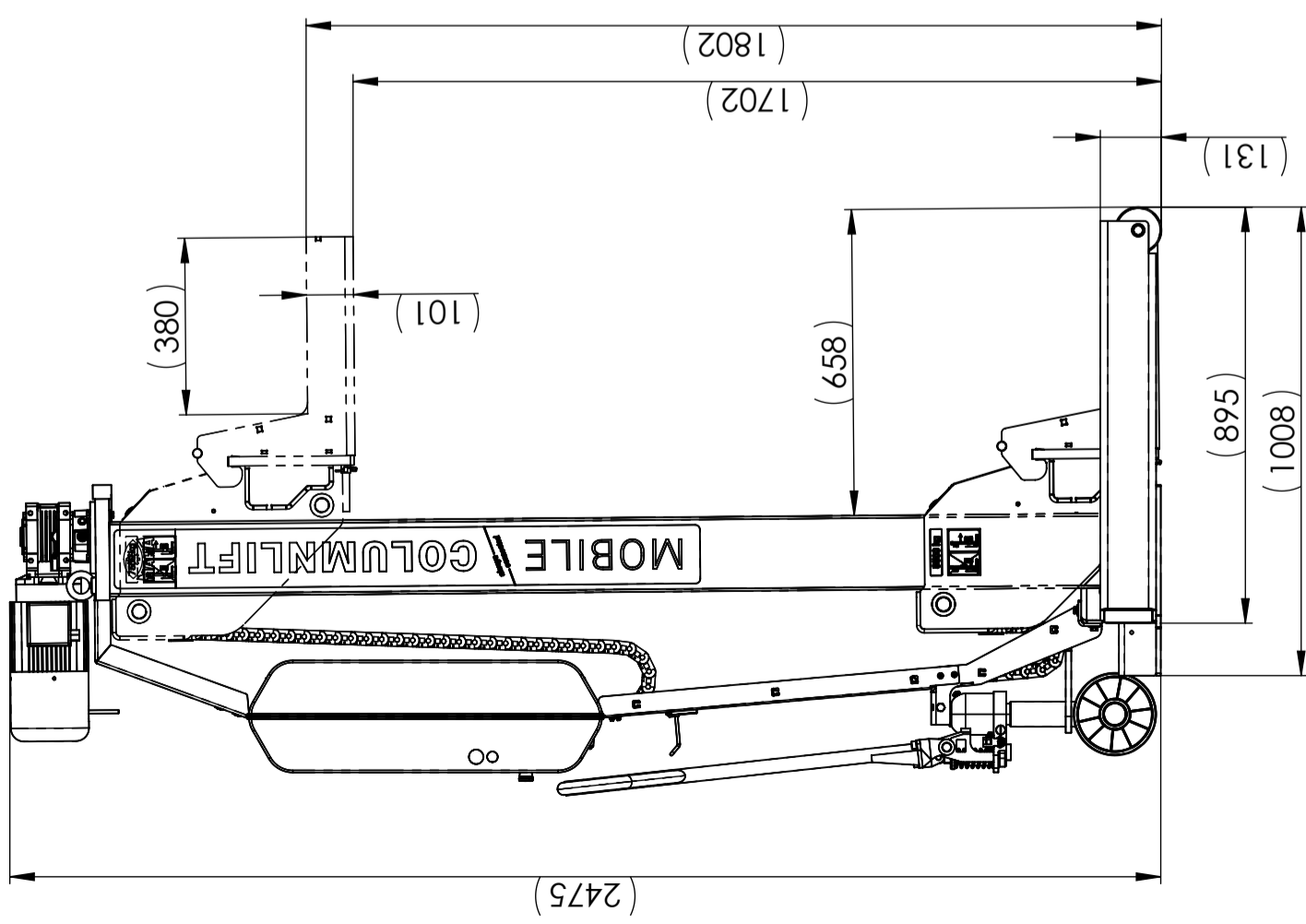

Declarations of Conformity



Original EC Declaration of Conformity

CE492501-en



MAHA Maschinenbau Haldenwang GmbH & Co. KG

herewith declares as a manufacturer its sole responsibility to ensure that the product named hereafter meets the safety and health regulations both in design and construction required by the directives stated below. This declaration becomes void if any change is made to the product that was not approved by named company beforehand.

Model

C_RGA 7.5 UC
C_RGA 8.5 UC

VP Number

VP 451191 | VP 451193 | VP 451195
VP 451196 | VP 451197

Designation

Mobile Column Lift

Directives

2006/42/EC
2014/30/EU

Standards

DIN EN 1493:2023-04
DIN EN 60204-1:2019-06

Person Authorised to Compile the Technical File

Ralf Kerkmeier
MAHA Maschinenbau Haldenwang GmbH & Co. KG, Hoyen 20, 87490 Haldenwang, Germany

Haldenwang, 2023-09-29

Andreas Maier
Authorised CE Representative

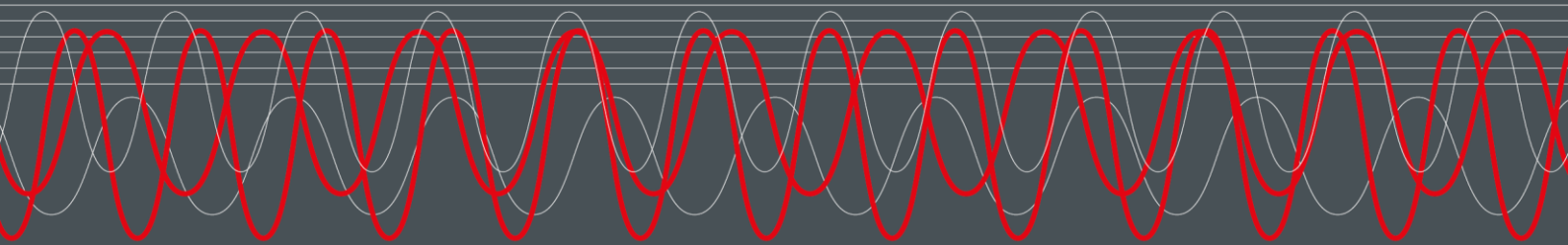

MAHA MASCHINENBAU HALDENWANG GMBH & CO. KG

Hoyen 20
87490 Haldenwang
Germany

☎ +49 8374 585 0
✉ maha@maha.de
🌐 maha.de